



MODEL **210-16**
610-16

Altitude Valve For Two-Way Flow



- Accurate and Repeatable Level Control
- Drip Tight Positive Shut-off
- Reliable Hydraulic Operation
- Easily Adjustable Control
- Completely Automatic Operation

The Cla-Val Model 210-16/610-16 Altitude Valve controls the high water level in reservoirs without the need for floats or other devices. It is a non-throttling valve that remains fully open until the shut off point is reached. This valve closes at a high water level, and opens for return flow when the pressure at the valve inlet is less than the reservoir pressure.

This valve is hydraulically operated and pilot controlled. The pilot control operates on the differential in forces between a spring load and the water level in the reservoir. When the force of the spring is overcome by the force of the reservoir head, the pilot closes the main valve. The desired high water level is set by adjusting the spring force. The pilot control measures the reservoir head through a customer supplied sensing line* connected directly to the reservoir.

This valve can also be furnished with auxiliary controls to meet the need for multiple functions, such as: pressure sustaining, pressure reduction, rate of flow control, solenoid override, etc.

Schematic Diagram

Item	Description
1	Hytrol (Main Valve)
2	CDS6 Altitude Control
3	X101 Valve Position Indicator
4	Bell Reducer
5	Check Valve
6	CK2 Cock
7	CV Flow Control (Closing)

Optional Features

Item	Description
A	X46A Flow Clean Strainer
B	CK2 Cock (Isolation Valve)
H	Dry Drain
S	CV Flow Control (Opening)
Y	X43 "Y" Strainer

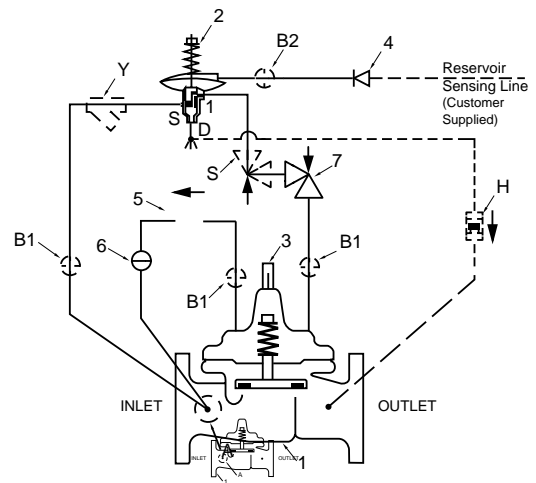

Typical Applications

Used on reservoirs where water is withdrawn through the Altitude Valve. The valve closes at the high water level and opens for return flow when the pressure at the valve inlet lowers below the reservoir pressure.

For more information see data sheet E-CDS6

*Note: The reservoir pressure sensing line should be 3/4" minimum I.D. installed with a 2° slope from valve to reservoir to avoid air pockets.

We recommend protecting tubing and valve from freezing temperatures.

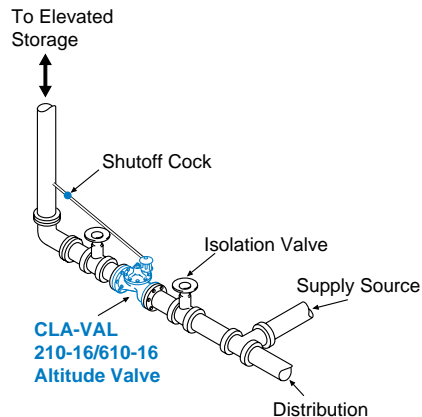

Model 210-16 (Uses Basic Valve Model 100-01)

Pressure Ratings (Recommended Maximum Pressure - psi)

Valve Body & Cover		Pressure Class			
		Flanged			Screwed
Grade	Material	ANSI Standards*	150 lb.	300 lb.	End** Details
ASTM A-536	Ductile Iron	B16.42	250	400	400
ASTM A216-WCB	Cast Steel	B16.5	285	400	400
ASTM B62	Bronze	B16.24	225	400	400
Type 304	Stainless Steel	B16.5	285	400	400
356-T6	Aluminum	B16.1	275	—	—

Note: *ANSI standards are for flange dimensions only.
Flanged valves are available faced but not drilled.
** End Details machined to ANSI B2.1 specifications.

Cover Capacity

Liquid Volume Displaced from Diaphragm Chamber When Valve Opens			
Valve Size	Displacement	Valve Size	Displacement
2"	.032 gal	10"	2.51 gal
2 - 1/2"	.043 gal	12"	4.00 gal
3"	.080 gal	14"	6.50 gal
4"	.169 gal	16"	9.57 gal
6"	.531 gal	24"	29.00 gal
8"	1.26 gal		

Materials

Component	Material Options				
Body & Cover	Ductile Iron	Cast Steel	Bronze	Stainless Steel	Aluminum
Available Sizes	2" - 16", 24"	2" - 16", 24"	2" - 16", 24"	2" - 16", 24"	2" - 16", 24"
Disc Retainer & Diaphragm Washer	Cast Iron	Cast Steel	Bronze	Stainless Steel	Aluminum
Trim: Disc Guide,	Bronze is standard.				
Seat & Cover Bearing	Stainless Steel is optional.			Stainless Steel is standard.	
Disc	Buna-N® Rubber				
Diaphragm	Nylon Reinforced Buna-N® Rubber				
Stem, Nut & Spring	Stainless Steel				

Dimensions (In inches)

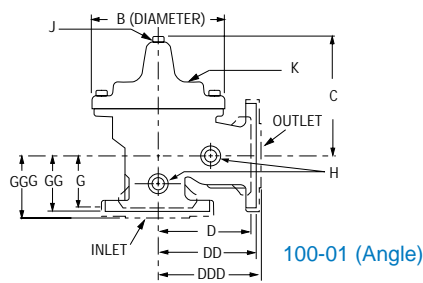
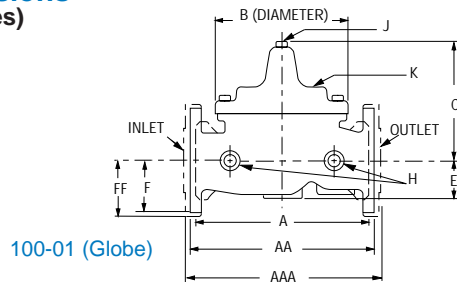

2" Globe, Screwed



4" Angle, Flanged

Valve Size (Inches)	2	2 1/2	3	4	6	8	10	12	14	16	24
A Screwed	9.38	11.00	12.50	—	—	—	—	—	—	—	—
AA 150 ANSI	9.38	11.00	12.00	15.00	20.00	25.38	29.75	34.00	39.00	41.38	61.50
AAA 300 ANSI	10.00	11.62	13.25	15.62	21.00	26.38	31.12	35.50	40.50	43.50	—
B Dia.	6.62	8.00	9.12	11.50	15.75	20.00	23.62	28.00	32.75	35.50	53.16
C Max.	6.50	7.56	8.19	10.62	13.38	16.00	17.12	20.88	24.19	25.00	43.93
D Screwed	4.75	5.50	6.25	—	—	—	—	—	—	—	—
DD 150 ANSI	4.75	5.50	6.00	7.50	10.00	12.75	14.88	17.00	19.50	20.81	—
DDD 300 ANSI	5.00	5.88	6.38	7.88	10.50	13.25	15.56	17.75	20.25	21.62	—
E	1.50	1.69	2.06	3.19	4.31	5.31	9.25	10.75	12.62	15.50	17.75
F 150 ANSI	3.00	3.50	3.75	4.50	5.50	6.75	8.00	9.50	10.50	11.75	19.25
FF 300 ANSI	3.25	3.75	4.13	5.00	6.25	7.50	8.75	10.25	11.50	12.75	—
G Screwed	3.25	4.00	4.50	—	—	—	—	—	—	—	—
GG 150 ANSI	3.25	4.00	4.00	5.00	6.00	8.00	8.62	13.75	14.88	15.69	—
GGG 300 ANSI	3.50	4.31	4.38	5.31	6.50	8.50	9.31	14.50	15.62	16.50	—
H NPT Body Tapping	3/8	1/2	1/2	3/4	3/4	1	1	1	1	1	1
J NPT Cover Center Plug	1/2	1/2	1/2	3/4	3/4	1	1	1 1/4	1 1/2	2	1 1/2
K NPT Cover Tapping	3/8	1/2	1/2	3/4	3/4	1	1	1	1	1	1
Valve Stem Internal											
Thread UNF	10-32	10-32	1/4-28	1/4-28	3/8-24	3/8-24	3/8-24	3/8-24	3/8-24	1/2-20	3/4-16
Stem Travel	0.6	0.7	0.8	1.1	1.7	2.3	2.8	3.4	4.0	4.5	6.50
Approx. Ship Wt. Lbs.	35	50	70	140	285	500	780	1165	1600	2265	6200

Model 610-16 (Uses Basic Valve Model 100-20)

Pressure Ratings (Recommended Maximum Pressure - psi)

Valve Body & Cover		Pressure Class		
		Flanged		
Grade	Material	ANSI Standards*	150 lb.	300 lb.
ASTM A-536	Ductile Iron	B16.42	250	400
ASTM A216-WCB	Cast Steel	B16.5	285	400
ASTM B62	Bronze	B16.24	225	400
Type 304	Stainless Steel	B16.5	285	400
356-T6	Aluminum	B16.1	275	—

Note: *ANSI standards are for flange dimensions only.
Flanged valves are available faced but not drilled.

Cover Capacity

Liquid Volume Displaced from Diaphragm Chamber When Valve Opens			
Valve Size	Displacement	Valve Size	Displacement
3"	.032 gal	12"	2.51 gal
4"	.080 gal	16"	4.00 gal
6"	.169 gal	20"	9.57 gal
8"	.531 gal	24"	9.57 gal
10"	1.26 gal		

Materials

Component	Material Options				
Body & Cover	Ductile Iron	Cast Steel	Bronze	Stainless Steel	Aluminum
Available Sizes	3"-24"	3"-24"	3"-24"	3"-24"	3"-24"
Disc Retainer & Diaphragm Washer	Cast Iron	Cast Steel	Bronze	Stainless Steel	Aluminum
Trim: Disc Guide, Seat & Cover Bearing	Bronze is standard. Stainless Steel is optional.			Stainless Steel is standard.	
Disc	Buna-N® Rubber				
Diaphragm	Nylon Reinforced Buna-N® Rubber				
Stem, Nut & Spring	Stainless Steel				



3" Globe, Flanged

Dimensions (In inches)

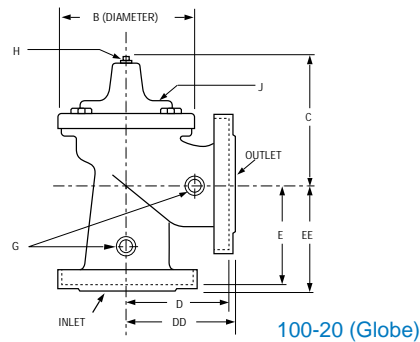
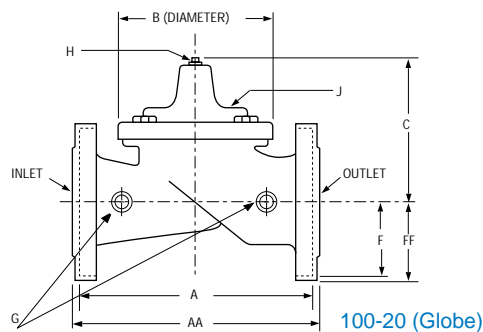

































6" Angle, Flanged

VALVE SIZE (Inches)	3	4	6	8	10	12	16	20	24
A 150 ANSI	10.25	13.88	17.75	21.38	26.00	30.00	35.00	48.00	48.00
AA 300 ANSI	11.00	14.50	18.62	22.38	27.38	31.50	36.62	49.62	49.75
B DIA.	6.62	9.12	11.50	15.75	20.00	23.62	28.00	35.44	35.44
C Max.	7.00	8.62	11.62	15.00	17.88	21.00	25.75	31.00	31.00
D 150 ANSI	—	6.94	8.88	10.69	—	—	—	—	—
DD 300 ANSI	—	7.25	9.38	11.19	—	—	—	—	—
E 150 ANSI	—	5.50	6.75	7.25	—	—	—	—	—
EE 300 ANSI	—	5.81	7.25	7.75	—	—	—	—	—
F 150 ANSI	3.75	4.50	5.50	6.75	8.00	9.50	11.75	14.56	17.00
FF 300 ANSI	4.12	5.00	6.25	7.50	8.75	10.25	12.75	16.06	19.00
G NPT Body Tapping	3/8	1/2	3/4	3/4	1	1	1	1	1
H NPT Cover Center Plug	1/2	1/2	3/4	3/4	1	1	1 1/4	2	2
J NPT Cover Tapping	3/8	1/2	3/4	3/4	1	1	1	1	1
Valve Stem Internal Thread UNF	10-32	1/4-28	1/4-28	3/8-24	3/8-24	3/8-24	3/8-24	1/2-20	1/2-20
Stem Travel	0.6	0.8	1.1	1.7	2.3	2.8	3.4	4.5	4.5
Approximate Shipping Weight Lbs.	45	85	195	330	625	900	1380	2551	2733

Valve Selection

These Symbols  and  Indicate Available Sizes

		Size	1 1/4"	1 1/2"	2"	2 1/2"	3"	4"	6"	8"	10"	12"	14"	16"	20"	24"	
End Details		Screwed	Screwed or Flanged					Flanged									
Model 210-16	Basic Valve 100-01	Globe															
		Angle															
	Suggested Flow GPM	Max. Continuous				208	300	460	800	1800	3100	4900	7000	8500	11000		28000
		Max. Intermittent				260	370	580	990	2250	3900	6150	8720	10340	13700		35000
Model 610-16	Basic Valve 100-20	Globe					 **										
		Angle															
	Suggested Flow-GPM	Max. Continuous						260	580	1025	2300	4100	6400		9230	16500	16500

*610-16 is the reduced internal port size version of the 210-16.

Refer to the 100-01 or the 100-20 Technical Data Sheet for basic valve options.

Max Continuous Flow based on 20 fps (100-01), 25 fps (100-20)

Max Intermittent Flow based on 25 fps (100-01)

*Flanged End Detail Only

Pilot System Dimensions (In Inches)

We recommend providing adequate space around valve for maintenance work

VALVE SIZE	1 1/4" & 1 1/2"	2	2 1/2"	3"	4"	6"	8"	10"	12"	14"	16"	20"	24"
X Max.	—	19.25	20.50	22.00	24.50	28.00	30.00	30.75	31.00	31.50	32.25	35.00	35.00
Y Max.	—	4.00	4.00	4.75	6.00	8.00	10.25	12.00	14.25	16.75	18.00	18.00	27.00
Z Max.	—	16.00	16.75	16.75	18.00	20.50	22.50	24.50	26.50	29.00	30.50	32.00	41.00

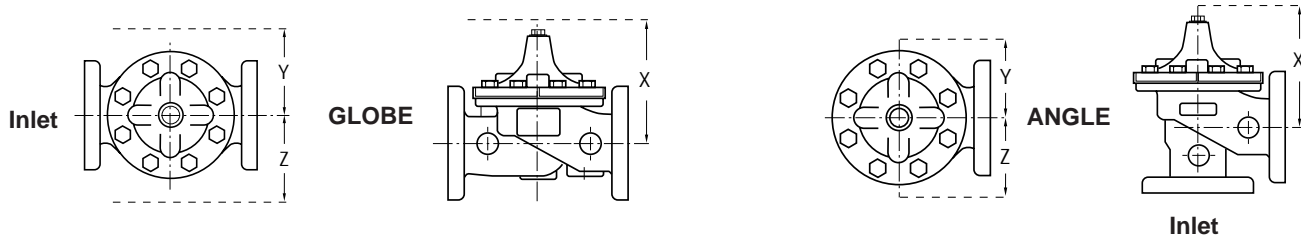

Pilot System Specifications

Adjustment Ranges

- 5 - 40 ft.
- 30 - 80 ft.
- 70 - 120 ft.
- 110 - 160 ft.
- 150 - 200 ft.

Temperature Range

Water: to 180°F

If flowing line pressure is less than 10 psi, consult factory for full details.

If inlet pressure is above 150 psi, consult factory for recommendations.

Materials

Standard Pilot System Materials

- Pilot Control: Bronze ASTM B62
- Trim: Stainless Steel Type 303
- Rubber: Buna-N® Synthetic Rubber

Optional Pilot System Materials

Pilot Systems are available with optional Aluminum, Stainless Steel or Monel materials at extra cost.

Valve position indicator is standard.

When Ordering Please Specify

1. Catalog No. 210-16 or No. 610-16
2. Valve Size
3. Pattern - Globe or Angle
4. Pressure Class
5. Screwed or Flanged
6. Materials Desired
7. Adjustment Range
8. Desired Options
9. When Vertically Installed



E-210-16/610-16 (R-7/98)

CLA-VAL

PO Box 1325 Newport Beach CA 92659-0325
Phone: 949-722-4800 • Fax: 949-548-5441

CLA-VAL CANADA, LTD.

4687 Christie Drive
Beamsville, Ontario
Canada LOR 1B4
Phone: 905-563-4963
Fax: 905-563-4040

©COPYRIGHT CLA-VAL 1998 Printed in USA
Specifications subject to change without notice.

CLA-VAL SA

Chemin des Mesanges 1
CH-1032 Romanel/
Lausanne, Switzerland
Phone: 41-21-643-15-55
Fax: 41-21-643-15-50

www.cla-val.com

Represented By:

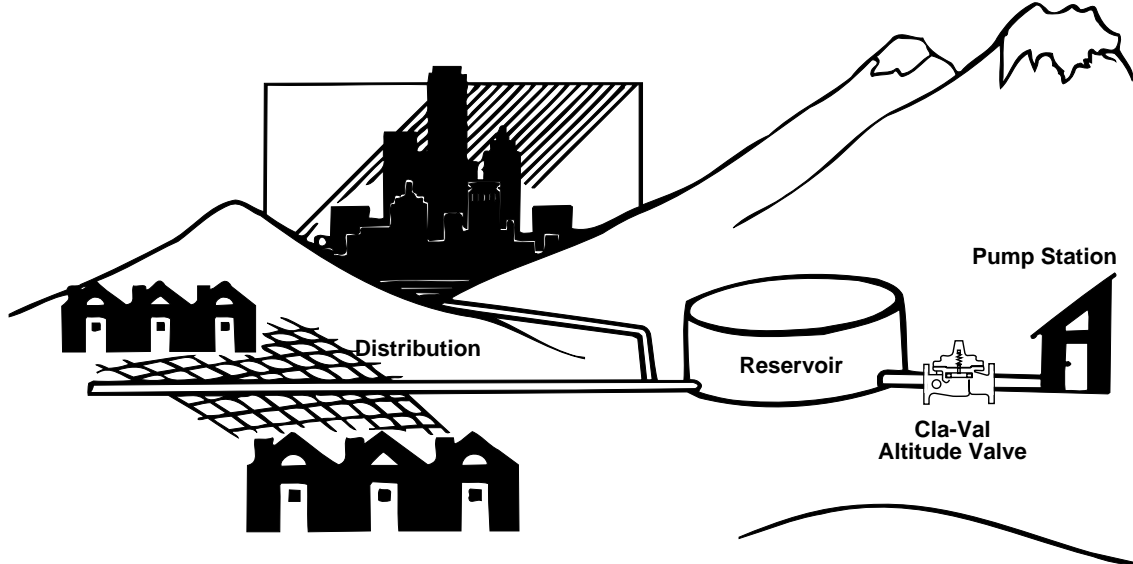

CLA-VAL LEVEL CONTROL VALVES

The water level of tanks and reservoirs can be controlled in many ways using automatic control valves. Fundamentally, all level control valves have in common the fact that they close on a high level in a tank or reservoir. To understand the various types of level control valves available, they can be grouped by the type of valve action. They form into two kinds of valve action: on-off or modulating. The on-off group of control valves provide a simple on-off high level shutoff function. The modulating group of control valves provide a variable amount of valve position and flow in relation to the changing water level in the tank. Within these two fundamental groups are combination level control valves, where a virtually unlimited number of other valve functions can be added to any valve, such as: back pressure, two-way flow, delayed opening, rate of flow control, check feature, solenoid override, ect.

ON-OFF GROUP

A simple, reliable way for smaller tank level control would be using a three-way float actuated pilot valve. The float pilot valve is mounted on the main hytrol valve for filling from the reservoir top, or the float pilot valve can be remotely mounted for reservoir filling from the bottom. (Cla-Val Series 124)

Larger reservoirs due to their size or height often require a "float-less" or altitude valve for level control. The pressure head of the reservoir is sensed through a separate line by the valve mounted pilot control which shifts to close the main hytrol valve when the reservoir is full. (Cla-Val Series 210)

When electricity is available at the reservoir site it can be used for operating a small solenoid pilot valve mounted on the main valve filling the reservoir. When the high level is reached a float switch or level probe signals the main hytrol valve to close by switching power to the solenoid pilot valve. (Cla-Val Series 136)

MODULATING GROUP

Tanks or reservoirs where the level must be held within closely controlled limits regardless of filling or lowering flow rates normally use a modulating type pilot control system arrangement. Modulating float valves are not normally recommended for straight on-off service. The pilot control senses the water level shift which in turn modulates the main hytrol valve to a new position between fully open and tight closed. (Cla-Val Series 427 and 428)

Reservoirs where the rising level is to match the closing of the valve also use a modulating type float pilot control system arrangement. As the reservoir fills the main hytrol valve is open then as the level approaches the shut off point the float pilot slowly modulates the valve closed. (Cla-Val Series 129)

Please call your Cla-Val regional office or sales agent for complete design assistance. Our goal is to provide the best automatic control valve solution for each application.