



# Two-Door Check Valve

## Series 582W

## Series 582

## Series 582G

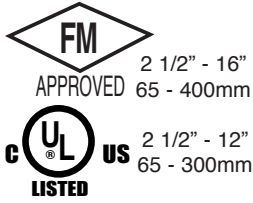

- New - Lower Head Loss Design
- New - Alignment Wings for ANSI 125, ISO PN10 & PN16 Mounting
- High Speed Anti-Slam Closure
- Stabilizer Spheres Prevent Vibration Wear
- Factory Mutual Approved / UL Listed
- Plain Ends or Grooved Ends

### SPECIFICATIONS

The two-door wafer check valve shall be compact wafer design, to fit between flanges or grooved ends. The check valve doors shall be spring-loaded closed, by means of one or more stainless steel torsion springs. Flow shall cause the doors to open and upon pump shut down, the torsion spring shall shut the doors, before reverse flow, for anti-slam closure.

Seating shall be resilient Buna-N®, watertight and molded to the body. Valves 6" and larger shall be supplied with an eye bolt for lifting. The valve shall be a Cla-Val Series 582W 2"-12" having alignment wings for mounting between ANSI 125, ISO PN10 or PN16 flanges or Series 582 (14"-60") for mounting between ANSI 125 or 150 flanges or Series 582G (2"-12") with grooved ends for mounting between groove end piping.

All materials of construction shall conform to ASTM specifications as follows:

All Cla-Val Series 582 Two-Door Check Valves utilize a torsion springs that very quickly shut the valve, before flow reversal. To minimize Slam / Water Hammer typically experienced with conventional swing check valves. Basically Two Door design valves, halves the travel distance from open valve to shut-off vs swing check valves and is the reason for the Anti-slam / Minimum Water Hammer feature. With extremely short laying lengths series 582W and Series 582 are space savings & an economical solution. The Series 582G with grooved ends provides for ease of installation and removal from pipelines. Although lighter in weight than conventional swing check valves, Cla-Val Two-Door Wafer Check Valves are designed for heavy-duty applications. For ease of installation, valves 6" and larger are supplied with lifting eye bolts. All materials conform to ASTM specifications, ensuring long lasting reliable performance.

<b>Valve Body:</b>	<b>Sealing Element:</b>	Buna-N®
Series 582W & 582G 2" - 12"	<b>Torsion Spring:</b>	316
Ductile Iron ASTM A536		Stainless Steel
Series 582 14" - 16"	<b>Hinge:</b>	316
Cast Iron ASTM A126, Class B		Stainless Steel
<b>Doors:</b>	<b>Stop:</b>	316
2" - 12" Bronze ASTM B584		Stainless Steel
14" - 60" Aluminum Bronze ASTM B148	<b>Sizes:</b>	2" to 60"

### Series 582 Pressure Loss Curve

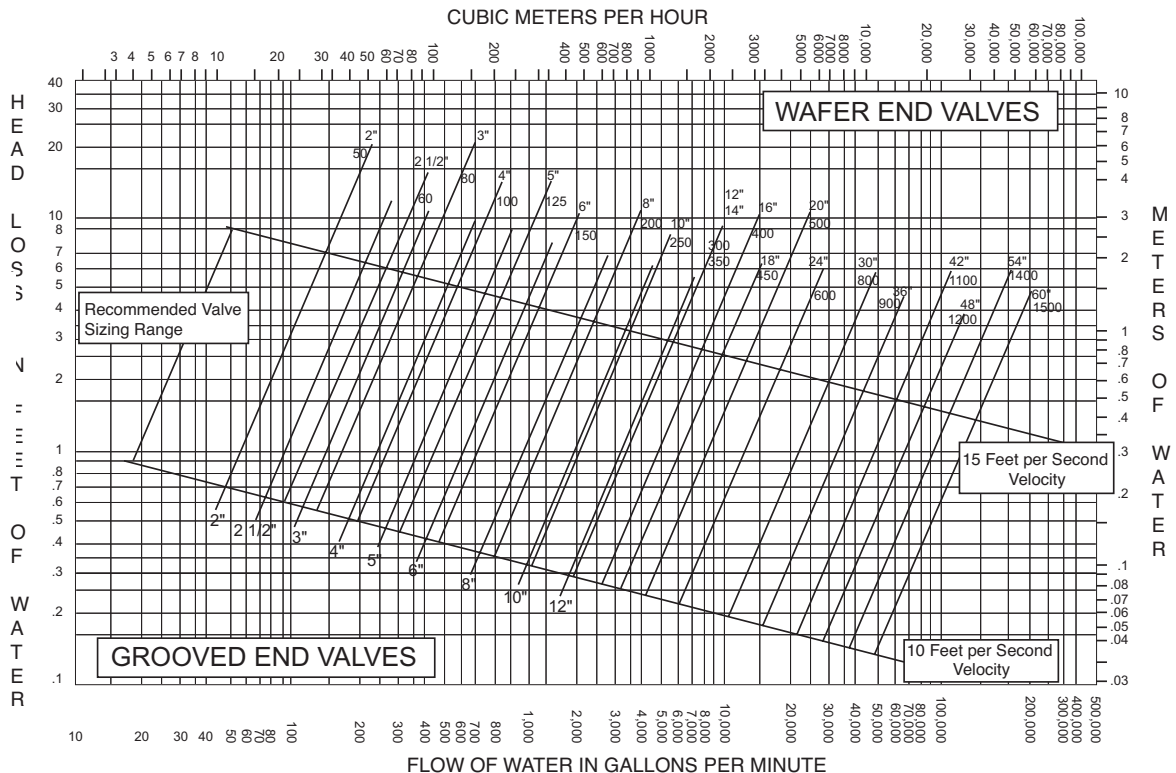

# Series 582 Two-Door Wafer Check Valve



APPROVED

2 1/2" - 16"  
65 - 400 mm



2 1/2" - 12"  
65 - 300 mm

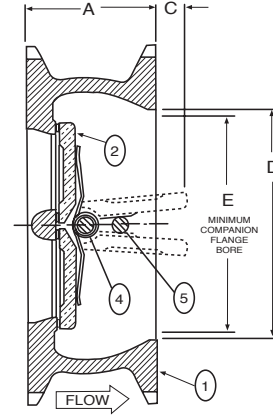
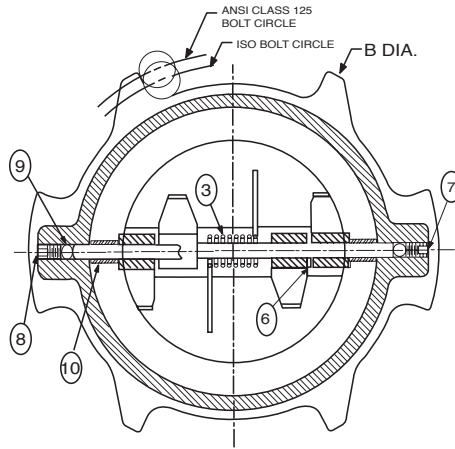

## Dimensions (In Inches)

Cla-Val Series 582 Two-Door Wafer Check Valve ANSI CLASS 125									Wafer	Grooved
Size	A	A2	B1	B2	C	D1	D2	E	Wt Lbs.	Wt Lbs.
2	2 1/8	4 21/32	4 1/8	5 1/8	3/16	2 9/16	2 3/8	1 15/16	4	4
2 1/2	2 3/8	4 29/32	4 7/8	6	5/16	3 1/16	2 7/8	2 5/16	5	5
3	2 5/8	5 5/16	5 3/8	5 5/8	1/2	3 11/16	3 1/2	2 7/8	7	8
4	2 5/8	5 3/8	6 7/8	7 3/4	1	4 5/8	4 1/2	3 7/8	9	9
5	3 1/4	5 23/32	7 3/4	7 9/16	1 1/8	5 11/16	5 9/16	4 13/16	13	13
6	3 3/4	6	8 3/4	8 5/8	1 1/4	6 3/4	6 5/8	5 3/4	19	18
8	5	6 23/32	11	12 1/4	1 5/16	8 3/4	8 5/8	7 5/8	38	30
10	5 1/2	7 23/32	13 3/8	13 3/4	2 1/2	10 7/8	10 3/4	9 9/16	65	56
12	7 1/8	8 3/16	16 1/8	17 3/8	2 3/8	12 7/8	12 3/4	11 3/8	94	81
14	7 1/4	N/A	17 3/4	N/A	3 1/4	14 3/4	N/A	12 1/2	187	N/A
16	7 1/2	N/A	20 1/4	N/A	4 1/2	16 3/8	N/A	15	270	N/A
18	8	N/A	21 5/8	N/A	5 3/8	18 3/8	N/A	17	330	N/A
20	8 3/8	N/A	23 1/8	N/A	6 3/8	20 1/4	N/A	19	424	N/A
24	8 3/4	N/A	28 1/4	N/A	8 1/2	24 1/4	N/A	23	589	N/A
30	12	N/A	34 3/4	N/A	9 1/2	30	N/A	28 1/2	1,112	N/A
36	14 1/2	N/A	41 1/4	N/A	12	36	N/A	34 1/2	1,864	N/A
42	17	N/A	48	N/A	13 3/4	42	N/A	40 1/2	2,889	N/A
48*	20 5/8	N/A	N/A	59 1/2	17	48	N/A	46 1/2	5,525	N/A
54*	21 1/4	N/A	N/A	66 1/4	20	54	N/A	52 1/2	7,000	N/A
60*	26	N/A	N/A	73	19	60	N/A	58 1/2	10,100	N/A

## INSTALLATION

Install the Cla-Val Series 582 Two-Door Wafer Check Valve between standard flanges in the horizontal or in the vertical, flow up, position.

## Dimensions (mm)

\*Threaded Flange Standard

Cla-Val Series 582 Two-Door Wafer Check Valve ANSI CLASS 125									Wafer	Grooved
Size	A	A2	B1	B2	C	D1	D2	E	Wt Lbs.	Wt Lbs.
2	54	118.3	104.8	130.2	4.8	65.1	60.9	49.2	1.8	1.8
2 1/2	60.3	124.6	123.8	152.4	7.9	77.8	73	58.7	2.3	2.3
3	66.7	134.9	136.5	136.5	12.7	93.7	88.9	73	3.2	3.6
4	66.7	136.5	174.6	196.8	25.4	117.5	114.3	98.4	4.1	4.1
5	82.6	145.2	196.8	192.1	28.6	144.5	141.3	122.2	5.9	5.9
6	95.3	152.4	222.2	219.1	31.8	171.4	168.3	146	8.6	8.2
8	127	170.6	279.4	311.3	33.3	222.2	219.1	193.7	17.2	13.6
10	139.7	197.6	339.7	349.2	63.5	276.2	273	242.9	29.5	25.4
12	181	208	409.6	441.3	60.3	327	323.7	288.9	42.6	36.7
14	184.1	N/A	450.8	N/A	82.6	365.1	N/A	317.5	84.8	N/A
16	190.5	N/A	514.3	N/A	114.3	415.9	N/A	381	122	N/A
18	203.2	N/A	549.3	N/A	136.5	466.7	N/A	431.8	150	N/A
20	212.7	N/A	606.4	N/A	161.9	514.3	N/A	482.6	192	N/A
24	222.2	N/A	717.5	N/A	215.9	615.9	N/A	584.2	268	N/A
30	304.8	N/A	882.6	N/A	241.3	768	N/A	723.9	504	N/A
36	368.3	N/A	1048	N/A	304.8	914.4	N/A	876.3	846	N/A
42	431.8	N/A	1219	N/A	349.2	1067	N/A	1029	1310	N/A
48*	523.9	N/A	N/A	1511	431.8	1219	N/A	1181	2506	N/A
54*	539.8	N/A	N/A	1683	508	1372	N/A	1336	3175	N/A
60*	660.4	N/A	N/A	1854	482.6	1524	N/A	1486	4580	N/A

## NOTE:

For horizontal flow this valve MUST Be installed with disc hinge pin in the VERTICAL position for proper operation.