



## Balanced Direct Acting Pressure Reducing Valve With Check Feature — Model 991



- A.S.S.E. Approved
- Balanced, Single Seat Design
- Operates In Any Position
- Easy Installation and Maintenance
- Stainless Steel Trim Standard
- Gauge Connections Standard
- All Bronze Body and Cover

The Cla-Val Model 990 Pressure Reducing Valve automatically reduces a higher inlet pressure to a steady lower downstream pressure due to the balanced design. This valve is an accurate regulator capable of holding downstream pressure to a predetermined amount, regardless of upstream pressure fluctuations. All moving parts are in a single, easily removable insert. For check valve action, the Model 991, in addition to its pressure reducing function, will close tight when a pressure reversal occurs.

### Typical Applications

**High rise buildings** use 990 Pressure Reducing Valves in various water systems (potable water, boiler feed air conditioning, etc.) to control pressure fluctuations between floors.

**Industrial plants** use 990 Pressure Reducing Valves between a high pressure supply system and equipment requiring lower pressure. Typically 990 Pressure Reducing Valves are used at supply connections for water heaters, boiler feed water or other process water systems.

**Municipal water systems** use 990 Pressure Reducing Valves at service connections in a high pressure distribution zone.

Depending on flow requirements, 990's may be installed in parallel. One 990 provides desired outlet pressure while the second 990 handles low flow conditions. If necessary, additional 990's can be added for more flow capacity. Also, the 990 is ideal for a low flow bypass around a larger Cla-Val 90 Series Pressure Reducing Valve.

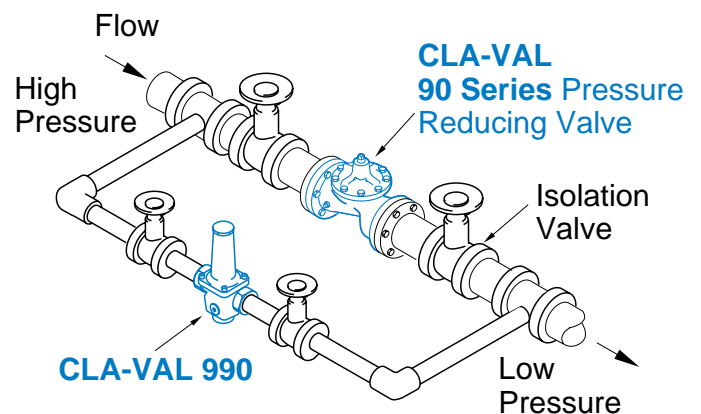
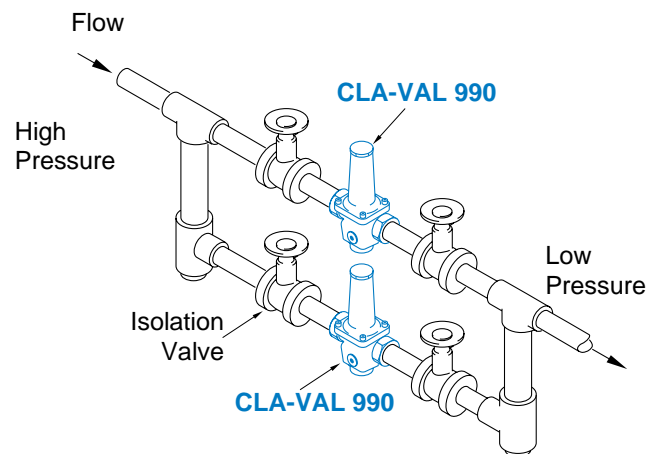

## Valve Operation

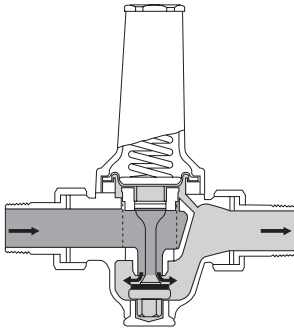

**Flow Condition**

When flow begins, the pressure underneath the diaphragm will drop, causing the spring to open the valve. As demand is satisfied and the downstream pressure increases, the pressure under the diaphragm overcomes the spring force and closes the valve.

The inlet pressure acts equally against the disc and the piston/stem. This allows the opening and closing force to be controlled only by the downstream pressure acting on the underside of the diaphragm. By changing the spring pressure setting, the downstream pressure can be adjusted over a wide range.

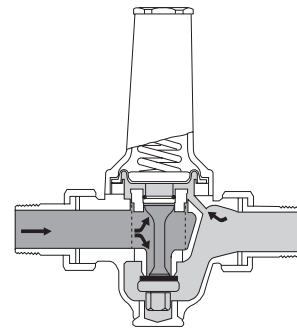

**No Flow Condition**

When there is no flow, the downstream pressure acts against the underside of the diaphragm, pulling the stem up causing a drip-tight seal.

### Check Valve Feature

Model 991 combines pressure reducing and check valve operation. When the downstream pressure is equal to, or greater than, the inlet pressure, the spring loaded disc assembly closes, regardless of the main stem position.

## Reduced Pressure Falloff

Unlike pilot controlled pressure reducing valves, direct acting valves are subject to "reduced pressure falloff". Reduced pressure falloff is the decrease in downstream regulated pressure that occurs when the flow increases. When the demand for flow increases, the valve must open wider and wider to permit the flow. The only way the valve can open is for the spring force to be greater than the hydraulic force under the diaphragm (the force trying to close the valve). Therefore, the downstream pressure must "fall off" or decrease before the spring can open the valve. All spring actuated direct acting valves have similar operating characteristics.

## Noise and Velocity Guidelines

Noise in water piping systems can sometimes be attributed to high velocities of water through the valve seat. In general, as the water velocity increases, the noise produced by the installation will increase.

Where noise levels are important, such as residences, hospitals, or schools, pipeline velocities should be in the range of 5 to 10 fps. The chart below shows velocity and the corresponding reduced pressure falloff. Generally, if these values for falloff are not exceeded, the 990 or 991 will produce the least amount of noise.

Velocity FPS	Reduced Pressure Falloff psi	
	1/2"-2"	2 1/2"
5.0	6.0	8.5
7.5	9.5	12.0
10.0	12.5	17.0

## Sizing Factors

Use the following step-by-step instructions for selecting Model 990 Pressure Reducing Valves:

### Step One

Determine the following:

1. Inlet pressure and desired outlet pressure
2. Maximum and minimum flow rate
3. Allowable reduced pressure falloff or maximum velocity based on acceptable noise level

### Step Two

Determine the pressure differential across the valve by subtracting the desired outlet pressure from the inlet pressure. If there will be any fluctuations in the inlet pressure, calculate both high and low differentials. At all times the differential must be at least 14.5 psi. When the differential is greater than 100 psi, use two valves in series.

### Step Three

Determine the valve size by using the Valve Capacity Charts on the next page. Start by entering the appropriate chart at your system's maximum flow rate. Locate the value for the maximum allowable Reduced Pressure Falloff (RPF) for your application. Select the valve size with a RPF value that is less than the maximum RPF.

If demand flow fluctuates beyond the capacity of one valve, use two or more Model 990's in parallel. Size one valve to handle the low flow, and the other valve(s) to handle the higher flows. Set the low flow valve approximately 3-4 psi higher than the other valve(s).

## Valve Capacity Charts

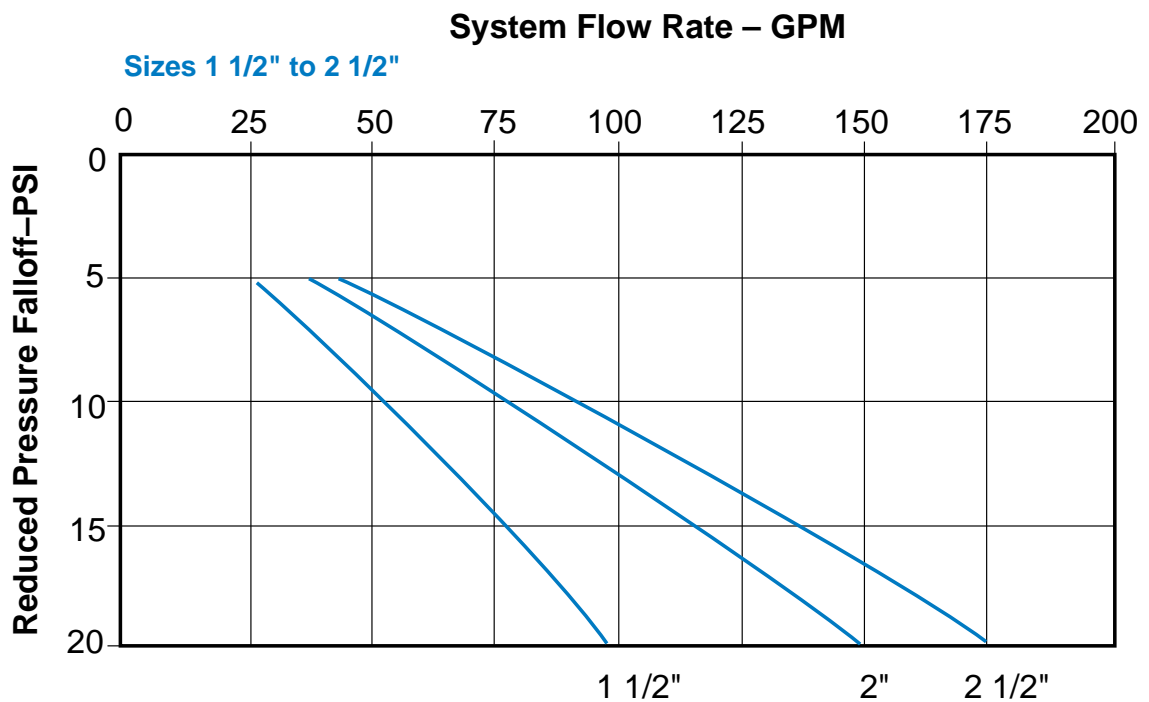
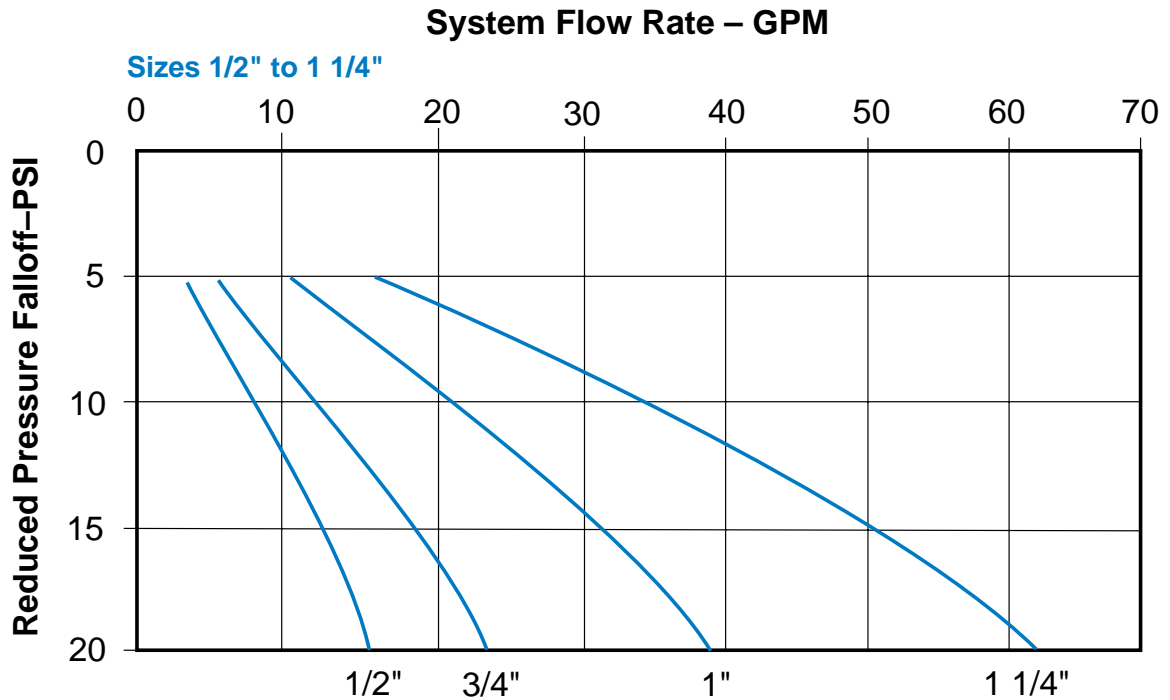

### Valve Selection Example

Given the following:

Inlet Pressure: 120 PSI  
Desired Outlet Pressure: 50 PSI  
Maximum Flow: 60 GPM  
Minimum Flow: 0 GPM  
Maximum Velocity: 7.5 FPS

From Velocity Guide Chart select falloff of 9.5 psi.  
Using the Capacity Chart, find the intersection of 9.5 psi and 60 GPM which is just above the 1 1/2" size. Choose the 2" size to keep the velocity below the desired maximum.



## Specifications

### Sizes

990: 1/2", 3/4", 1", 1 1/4", 1 1/2", 2", 2 1/2"  
 991: 1 1/2", 2" and 2 1/2"

### Temperature Range

Water: to 180°F Max

### Diaphragm:

Reinforced Neoprene

### End Details

Dual Union Tailpieces, NPT Threaded

### Materials

Body and Cover:  
 Bronze ASTM B62

**Disc:** Buna-N® Rubber

### Pressure Ratings

Maximum Inlet Pressure: 435 psi  
 Maximum Outlet Pressure: 142 psi  
 Minimum Differential Pressure: 14.5 psi

Strainer:  
 416 Stainless Steel

### Adjustment Ranges

Standard: 8 to 80 psi  
 Heavy: 70 to 140 psi

Valve Trim:  
 416 Stainless Steel

**A.S.S.E. Approved**  
 Standard 1003

## Dimensions (In Inches)

Size	A	B	C	D	E	Weight Lbs.
1/2"	5.875	5.125	2.218	2.281	7.343	2.8
3/4"	6.250	5.125	2.218	2.281	7.343	3.0
1"	7.250	5.593	2.375	2.563	7.968	4.6
1 1/4"	8.343	6.500	3.062	3.406	9.562	7.5
1 1/2"	9.500	7.593	3.562	4.219	11.155	5.8
2"	11.375	8.625	3.937	4.875	12.562	24.4
2 1/2"	12.187	9.000	3.937	4.875	12.937	27.6

Gauge connections 1/4" NPT

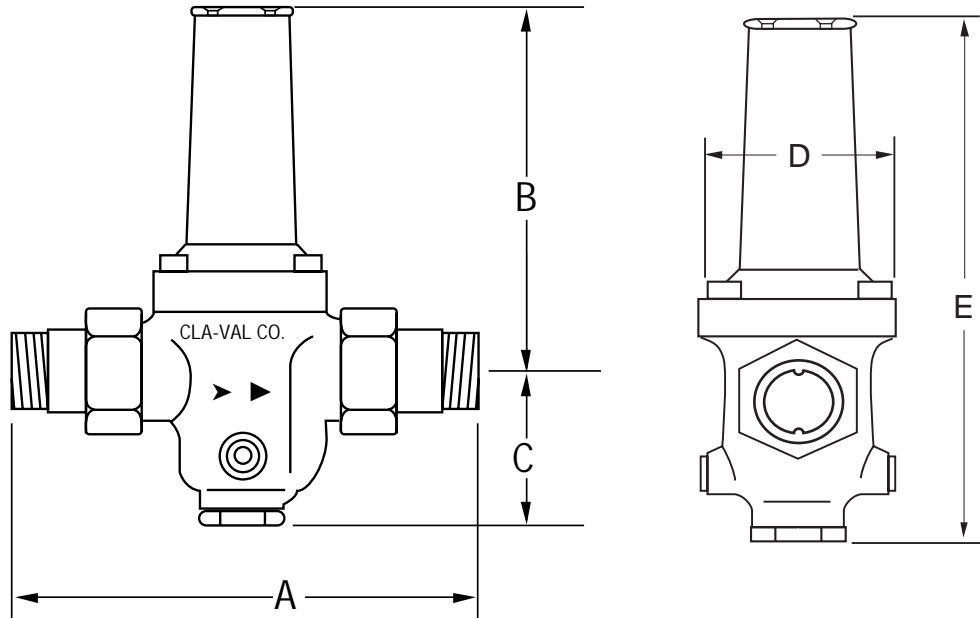

## When Ordering, Please Specify

1. Catalog No. 990 or  
 Catalog No. 991

2. Size

3. Adjustment Range



E-990 (R-7/98)

## CLA-VAL

PO Box 1325 Newport Beach CA 92659-0325  
 Phone: 949-722-4800 • Fax: 949-548-5441

### CLA-VAL CANADA, LTD.

4687 Christie Drive  
 Beamsville, Ontario  
 Canada LOR 1B4  
 Phone: 905-563-4963  
 Fax: 905-563-4040

### CLA-VAL SA

Chemin des Mesanges 1  
 CH-1032 Romanel/  
 Lausanne, Switzerland  
 Phone: 41-21-643-15-55  
 Fax: 41-21-643-15-50

©COPYRIGHT CLA-VAL 1998 Printed in USA  
 Specifications subject to change without notice.

[www.cla-val.com](http://www.cla-val.com)

## Represented By