



ALTITUDE PILOT CONTROL



- **Very Accurate and Reliable**
- **Low Maintenance**
- **Bronze and Stainless Steel Wetted Parts**

The Cla-Val Model CDS6 Altitude Pilot Control is a spring-loaded, three-way, diaphragm-actuated control that provides high-level shutoff for Cla-Val 210 Series Altitude Control Valves. The CDS6 controls the high water level in a reservoir or tank without the need for floats or other devices. It is a non-throttling pilot that remains fully open until the reservoir reaches the high level shutoff point. High accuracy is assured by remotely sensing the pressure head of the reservoir or tank. The single adjusting nut can be easily set in the field to close the main valve when liquid level reaches the desired high level set-point within five adjustment ranges.

The CDS6 operating principle uses a differential in forces between the spring load and the hydraulic head of the fluid level in the reservoir or tank to activate the pilot valve of the control. When the force of the spring setting (or the desired high level shutoff point) is overcome by the force of the reservoir head, the pilot valve shifts positions automatically and closes the main valve. When the reservoir head is eight to ten inches less than the spring setting, the pilot valve shifts to open the main valve.

Dimensions

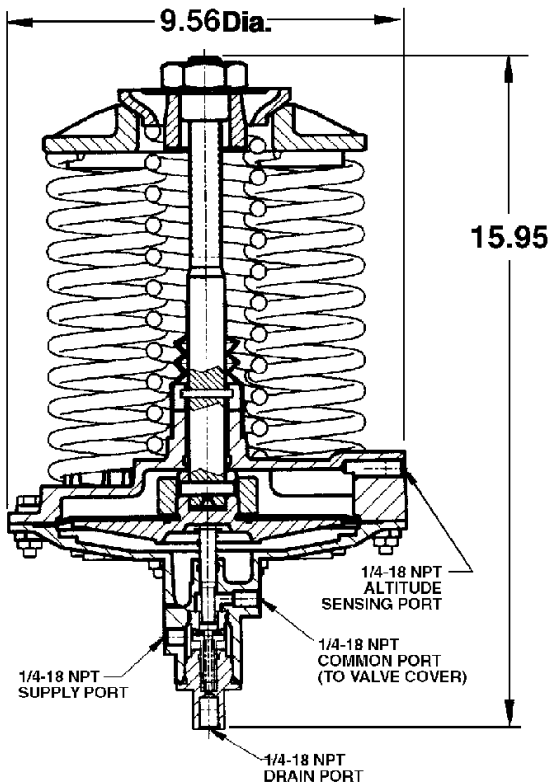

Specifications

Temperature Range:	Water to 180°F Max	Adjustment Ranges:
Materials:		5 - 40ft.
Body & Cover:	ASTM B-62	30 - 80ft.
Trim:	Brass & Stainless Steel	70 - 120ft.
Seals & Diaphragm:	Nitrile	110 - 160ft.
Optional Materials:	Consult Factory	150 - 200ft.
Pressure Rating:	250 PSI MAX	

Remote Sensing Connection

The CDS6 Altitude Pilot Control is normally supplied mounted on a Cla-Val 210 Series valve and should be installed in a horizontal run of pipe with the main valve cover UP. If the CDS6 is remotely mounted from the main valve, it is recommended to be installed with adjustment springs UP for ease of adjustment and servicing. Consult factory for recommendations.

After the Cla-Val 210 Series valve is installed in the line, it is necessary to install a sensing line from the CDS6 control to the reservoir. The sensing line should be 3/4" or larger copper tubing or Schedule 40 PVC pipe. Galvanized pipe is not recommended. The line should slope upward from the CDS6 toward the reservoir to self purge air out of the line. The slope of the sensing line should not have high points that would entrap air. The line connection point on the reservoir should be a minimum 12" to 18" above the center line of the control.

NOTE: The sensing line should not be installed into the flowing line between the valve and reservoir, or to a turbulent area, which may not reflect the true reservoir head.

Note: We recommend protecting tubing and valve from freezing temperatures.

