



Pressure Reducing Control Valves



CRA



CRD

- Direct Acting
- Hydraulic or Pneumatic Operation
- Simplified Design, Easy Adjustments
- Operates in Any Position
- Gauge Connection Port

The Models CRA and CRD Pressure Reducing Control automatically reduce a higher inlet pressure to a lower outlet pressure. They are direct acting, spring loaded, diaphragm type control regulators that operate hydraulically or pneumatically. These valves are held open by the force of the compression spring above the diaphragm, and close when the downstream pressure acting on the underside of the diaphragm exceeds the spring setting. The CRD senses downstream pressure directly and the CRA senses downstream pressure remotely.

Flow through the control responds to changes in downstream pressure. Turning the adjusting screw clockwise increases the delivery pressure, and turning it counterclockwise decreases the pressure. A resilient disc assures tight shut-off on dead-end service.

The Model CRA and CRD may be installed in any position. There is one inlet port and two outlets for either straight or angle installation. The second outlet port can be used for a gauge connection.

These valves are ideal small capacity regulators for applications such as water coolers, fountains, humidifiers, gas refrigerators, and air supply to tools and instruments (remote pressure sensing is available with the CRA). They also have numerous applications as pilot controls on many Cla-Val Automatic Control Valves.

Dimensions (In Inches)

CRA

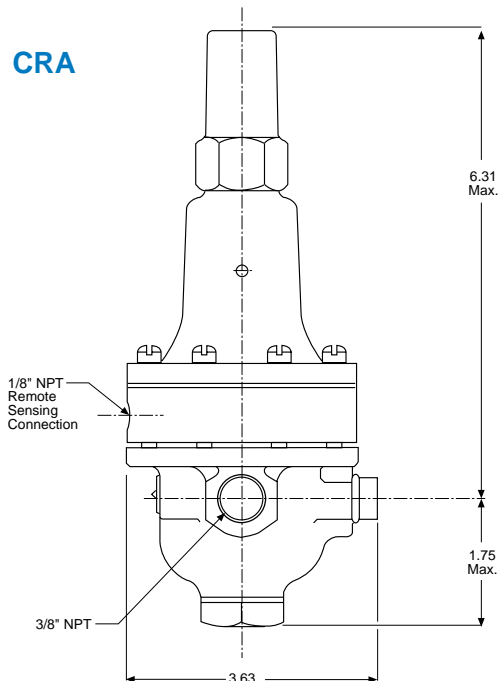

CRD

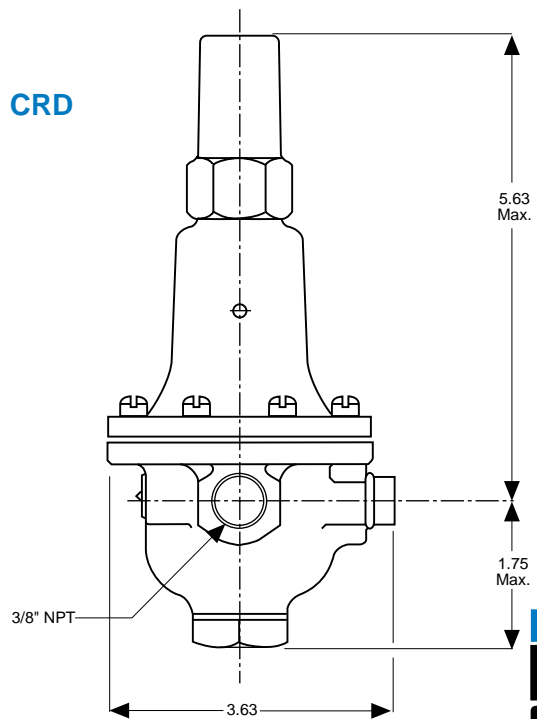

Specifications

Size	3/8" NPT screwed
Temperature Range	Water: to 180°F Max.
Materials	
Body & Cover:	Cast Bronze ASTM B-62
Trim:	Brass & Stainless Steel 303
Rubber:	Buna-N® Rubber
Optional Materials	Cast Aluminum 356-T6 Stainless Steel 303
Pressure Ratings	Cast Bronze 400 psi Max. Cast Aluminum 275 psi Max. Stainless Steel 400 psi Max.

Adjustment Ranges

psi:	2 - 7	feet of water:	4.5 - 15
	2 - 30		5 - 70
	15 - 75		35 - 170
	30 - 300		70 - 695

When Ordering, Please Specify

1. Catalog No. CRA or No. CRD
2. Adjustment Range Desired
3. Materials Desired

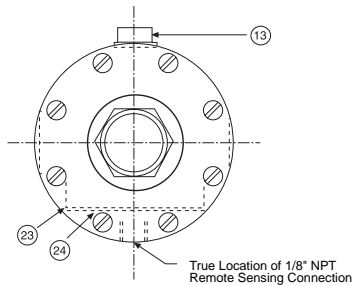

CRA

1. Cap
2. Screw, Adjusting
3. Jam Nut
4. Machine Screw—Fil H.D.
5. Cover
6. Spring Guide
7. Spring
8. Hex Nut
9. Diaphragm Washer (Upper)
10. Diaphragm
11. Plug (Body)
12. Gasket
13. Plug, 3/8 NPT
14. Disc Retainer Assembly
15. Yoke
16. Body & Seat Assembly
17. Belleville Washer
18. Powertrol Body
19. O-Ring
20. O-Ring
21. Diaphragm Washer (Lower)
22. Gasket
23. Nameplate Screw
24. Nameplate

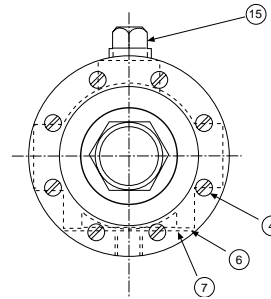
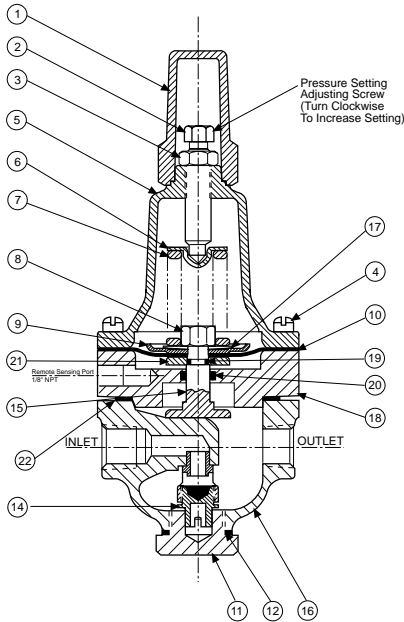

CRD

1. Cap
2. Screw, Adjusting
3. Jam Nut
4. Machine Screw—Fil. HD.
5. Cover
6. Nameplate Screw
7. Nameplate
8. Spring Guide
9. Spring
10. Hex Nut
11. Diaphragm Washer
12. Diaphragm
13. Plug (Body)
14. Gasket
15. Plug 3/8 NPT
16. Disc Retainer Assembly
17. Yoke
18. Body and Seat Assembly
19. Belleville Washer

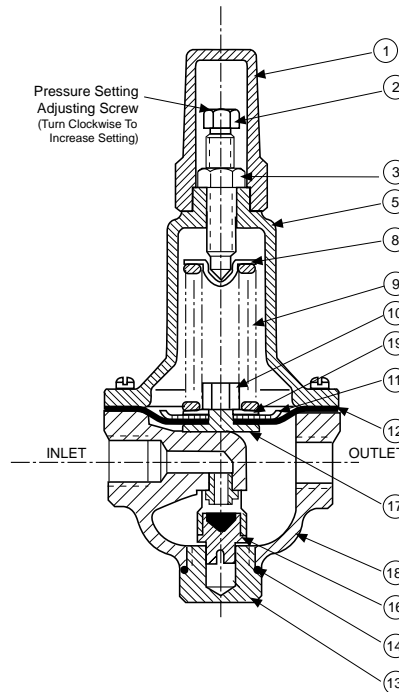

CLA-VAL

PO Box 1325 Newport Beach CA 92659-0325
Phone: 949-722-4800 • Fax: 949-548-5441

CLA-VAL CANADA, LTD.

4687 Christie Drive
Beamsville, Ontario
Canada LOR 1B4
Phone: 905-563-4963
Fax: 905-563-4040

CLA-VAL SA

Chemin des Mesanges 1
CH-1032 Romanel/
Lausanne, Switzerland
Phone: 41-21-643-15-55
Fax: 41-21-643-15-50

©COPYRIGHT CLA-VAL 1998 Printed in USA
Specifications subject to change without notice.

www.cla-val.com

Represented By: