

A-C Pump

Installation, Operation and Maintenance Instructions

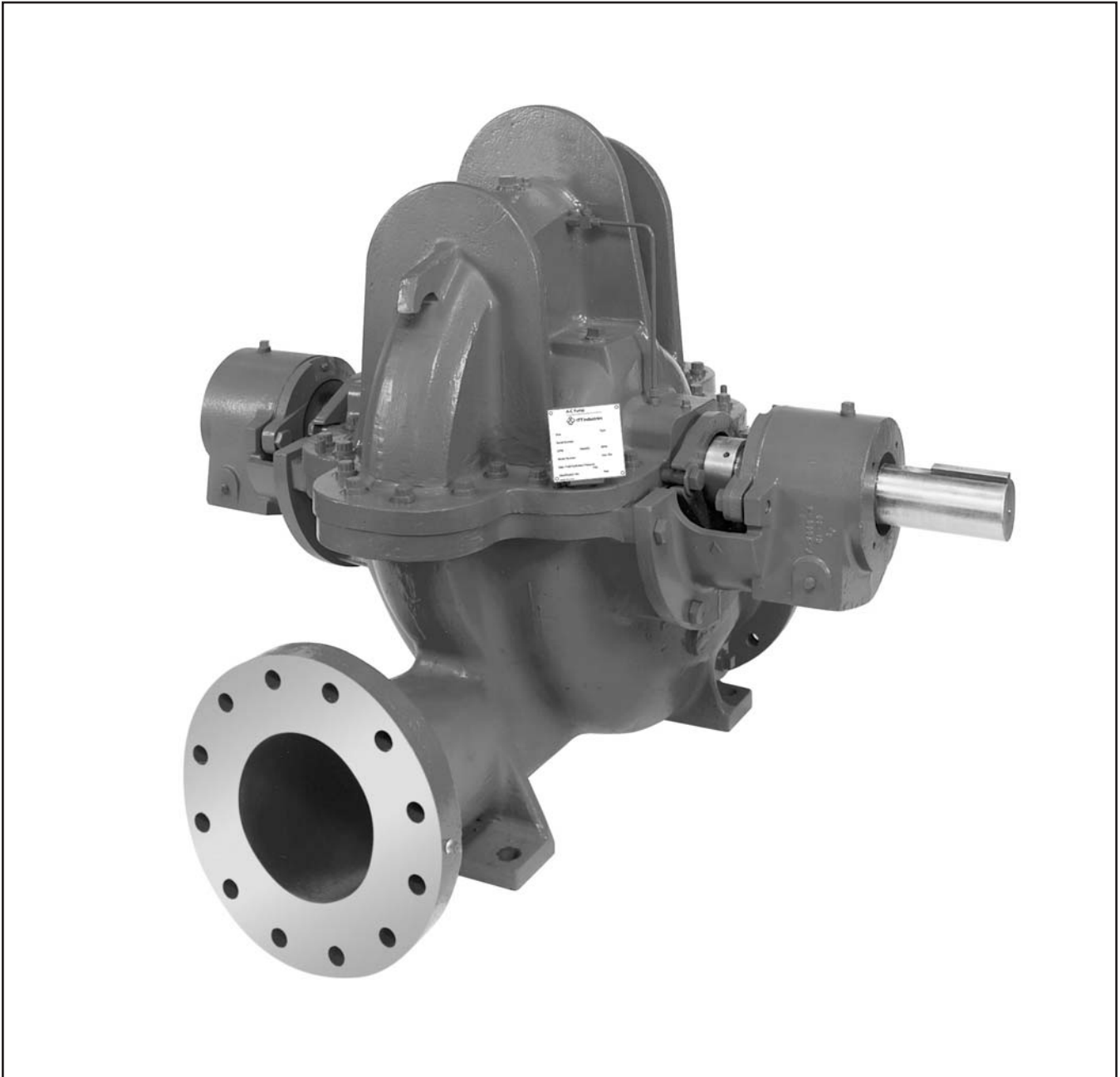

9100 Series

A-C Pump

 **ITT Industries**

Pump Safety Tips

Safety Apparel:

- Insulated work gloves when handling hot bearings or using bearing heater
- Heavy work gloves when handling parts with sharp edges, especially impellers
- Safety glasses (with side shields) for eye protection, especially in machine shop areas
- Steel-toed shoes for foot protection when handling parts, heavy tools, etc.
- Other personal protective equipment to protect against hazardous/toxic fluids

Coupling Guards:

- Never operate a pump without a coupling guard properly installed

Flanged Connections:

- Never force piping to make a connection with a pump
- Use only fasteners of the proper size and material
- Ensure there are no missing fasteners
- Beware of corroded or loose fasteners

Operation:

- Do not operate pump outside of parameters for which pump was sold
- Do not operate below minimum rated flow, or with suction/discharge valves closed
- Do not open vent or drain valves, or remove plugs while system is pressurized
- Do not operate pump if installed safety devices have been disconnected

Maintenance Safety:

- Always lock out power
- Never use heat to disassemble pump due to risk of explosion from trapped liquid
- Ensure pump is isolated from system and pressure is relieved before disassembling pump, removing plugs, or disconnecting piping
- Use proper lifting and supporting equipment to prevent serious injury
- Observe proper decontamination procedures
- Know and follow company safety regulations

Observe all cautions and warnings highlighted in pump Installation, Operation, and Maintenance Instructions .

IMPORTANT SAFETY REMINDER

To: *Our Valued Customers*

A-C Pumps will provide safe, trouble-free service when properly installed, maintained, and operated. We have an extensive network of experienced sales and service professionals to assist in maximizing your satisfaction with our products.

Safe installation, operation, and maintenance of A-C Pump equipment are an essential end user responsibility. This *Instruction, Operation, and Maintenance* (IOM) manual identifies specific safety risks that must be considered at all times during product life. Understanding and adhering to these safety warnings is mandatory to ensure personnel, property, and/or the environment will not be harmed. Adherence to these warnings alone, however, is not sufficient — it is anticipated that the end user will also comply with industry and corporate safety standards. Identifying and eliminating unsafe installation, operating and maintenance practices is the responsibility of all individuals involved in the installation, operation, and maintenance of industrial equipment.

Specific to pumping equipment, two significant risks bear reinforcement above and beyond normal safety precautions.



WARNING

1

Operation of any pumping system with a blocked suction and discharge must be avoided in all cases. Operation, even for a brief period under these conditions, can cause superheating of enclosed pumpage and result in a violent explosion. All necessary measures must be taken by the end user to ensure this condition is avoided.



WARNING

2

Pumping equipment Instruction, Operation, and Maintenance manuals clearly identify accepted methods for disassembling pumping units. These methods must be adhered to. Specifically, applying heat to impellers and/or impeller retaining devices to aid in their removal is strictly forbidden. Trapped liquid can rapidly expand and result in a violent explosion and injury.

Please take the time to review and understand the safe installation, operation, and maintenance guidelines outlined in this manual.

FOREWORD

This manual provides instructions for the Installation, Operation, and Maintenance of the A-C Pump 9100 Series Double Suction, Horizontally Split Case pump. This manual covers the standard product plus common options that are available. For special options, supplemental instructions are supplied. **This manual must be read and understood before installation and maintenance.**

The design, materials, and workmanship incorporated in the construction of A-C pumps make them capable of giving long, trouble-free service. The life and satisfactory service of any mechanical unit, however, is enhanced and extended by correct application, proper installation, periodic inspection, condition monitoring and careful maintenance. This instruction manual was prepared to assist operators in understanding the construction and the correct methods of installing, operating, and maintaining these pumps.

ITT Industries - A-C Pump shall not be liable for physical injury, damage or delays caused by a failure to observe the instructions for Installation, Operation, and Maintenance contained in this manual.



NOTE: When pumping unit is installed in a potentially explosive atmosphere, the instructions after the Ex symbol must be followed. Personal injury and/or equipment damage may occur if these instructions are not followed. If there is any question regarding these requirements or if the equipment is to be modified, please contact an A-C Pump representative before proceeding.

Warranty is valid only when genuine ITT Industries - A-C Pump parts are used.

Use of the equipment on a service other than stated in the order will nullify the warranty, unless written approval is obtained in advance from ITT Industries, A-C Pump.

Supervision by an authorized ITT Industries - A-C Pump representative is recommended to assure proper installation.

Additional manuals can be obtained by contacting your local ITT Industries - A-C Pump representative, by calling 1-800-446-8537, or visiting our website at www.acpump.com.

THIS MANUAL EXPLAINS

- Proper Installation
- Start-up Procedures
- Operation Procedures
- Routine Maintenance
- Pump Overhaul
- Troubleshooting
- Ordering Spare or Repair Parts

TABLE OF CONTENTS

PAGE		SECTION
7	SAFETY	1
11	GENERAL INFORMATION	2
13	INSTALLATION	3
25	OPERATION	4
29	PREVENTIVE MAINTENANCE	5
37	DISASSEMBLY & REASSEMBLY	6
53	APPENDICES	7

SAFETY

DEFINITIONS 7
GENERAL PRECAUTIONS 8
EXPLOSION PREVENTION 8
SPECIAL ATEX CONSIDERATIONS 8
ATEX IDENTIFICATION 8
INTENDED USE 9
CONDITION MONITORING 9

DEFINITIONS

This pump has been designed for safe and reliable operation when properly used and maintained in accordance with instructions contained in this manual. A pump is a pressure containing device with rotating parts that can be hazardous. Operators and maintenance personnel must realize this and follow safety measures. ITT Industries - A-C Pump shall not be liable for physical injury, damage or delays caused by a failure to observe the instructions in this manual.

Throughout this manual the words **WARNING**, **CAUTION**, **ELECTRICAL**, **ATEX**, and **NOTE** are used to indicate procedures or situations which require special operator attention:

 **WARNING**
Operating procedure, practice, etc. which, if not correctly followed, could result in personal injury or loss of life.

 **CAUTION**
Operating procedure, practice, etc. which, if not followed, could result in damage or destruction of equipment.

 *If equipment is to be installed in a potentially explosive atmosphere and these procedures are not followed, personal injury or equipment damage from an explosion may result.*

 **NOTE:** *Particular care must be taken when the electrical power source to the equipment is energized.*

NOTE: *Operating procedure, condition, etc. which is essential to observe.*

EXAMPLES

  **WARNING**
Pump shall never be operated without coupling guard installed correctly.

 **CAUTION**
Throttling flow from the suction side may cause cavitation and pump damage.

 *Improper impeller adjustment could cause contact between the rotating and stationary parts, resulting in a spark and heat generation.*

 *Lock out driver power to prevent electric shock, accidental start-up and physical injury.*

NOTE: *Proper alignment is essential for long pump life.*

GENERAL PRECAUTIONS



WARNING

Personal injuries will result if procedures outlined in this manual are not followed.

		NEVER operate pump without coupling guard correctly installed.
		NEVER operate pump beyond the rated conditions to which the pump was sold.
		NEVER start pump without proper prime (sufficient liquid in pump casing).
		NEVER run pump below recommended minimum flow or when dry.

		ALWAYS lock out power to the driver before performing pump maintenance.
		NEVER operate pump without safety devices installed.
		NEVER operate pump with discharge valve closed.
		NEVER operate pump with suction valve closed.
		DO NOT change conditions of service without approval of an authorized A-C Pump representative.

EXPLOSION PREVENTION



In order to reduce the possibility of accidental explosions in atmospheres containing explosive gasses and/or dust, the instructions under the ATEX symbol must be closely followed. ATEX certification is a directive enforced in Europe for non-electrical and electrical equipment installed in Europe. ATEX requirements are not restricted to Europe, and are useful guidelines for equipment installed in any potentially explosive environment.

SPECIAL ATEX CONSIDERATIONS

All installation and operation instructions in this manual must be strictly adhered to. In addition, care must be taken to ensure that the equipment is properly maintained. This includes but is not limited to:

1. Monitoring the pump frame and liquid end temperature.
2. Maintaining proper bearing lubrication.
3. Ensuring that the pump is operated in the intended hydraulic range.

ATEX IDENTIFICATION

For a pumping unit (pump, seal, coupling, motor and pump accessories) to be certified for use in an ATEX classified environment, the proper ATEX identification must be present. The ATEX tag will be secured to the pump or the baseplate on which it is mounted. A typical tag will look like this:



The code directly below these symbols reads as follows:

II	=	Group 2
2	=	Category 2
G/D	=	Gas and Dust present
T4	=	Temperature class, can be T1 to T6 (see following table 1)

The CE and the Ex designate the ATEX compliance.

Table 1		
Code	Max permissible surface temperature, °F (°C)	Max permissible liquid temperature, °F (°C)
T1	842 (450)	700 (372)
T2	572 (300)	530 (277)
T3	392 (200)	350 (177)
T4	275 (135)	235 (113)
T5	212 (100)	Option not available
T6	185 (85)	Option not available

The code classification marked on the equipment should be in accordance with the specified area where the equipment will be installed. If it is not, please contact your ITT/A-C Pump representative before proceeding.

INTENDED USE

The ATEX conformance is only applicable when the pump unit is operated within its intended use. All instructions within this manual must be followed at all times. Operating, installing or maintaining the pump unit in any way that is not covered in this manual can cause serious personal injury or damage to the

equipment. This includes any modification to the equipment or use of parts not provided by ITT/A-C Pump. If there is any question regarding the intended use of the equipment please contact an ITT/A-C Pump representative before proceeding.

CONDITION MONITORING



For additional safety precautions, and where noted in this manual, condition monitoring devices should be used. This includes, but is not limited to:

- Pressure gauges
- Flow meters
- Level indicators
- Motor load readings
- Temperature detectors
- Bearing monitors
- Leak detectors
- PumpSmart control system

For assistance in selecting the proper instrumentation and its use, please contact your ITT/A-C Pump representative.

GENERAL INFORMATION

PUMP DESCRIPTION	11
NAMEPLATE INFORMATION	12
RECEIVING THE PUMP	13
Storage Requirements	13
Handling	13

PUMP DESCRIPTION

This product line consists of 12 sizes of double suction, horizontally split case pumps from size 10x6x22 through size 18x14x28.

Casing - The casing is close-grained Cast Iron or Ductile Iron, and is an axially-split double-volute design with suction and discharge flanges and mounting feet cast integral with the lower half casing. Tapped and plugged holes are provided for priming, vent, drain and gauge connections. Upper half casing is removable without disturbing suction or discharge piping. Flanges are (125/125#) (125/250#) (250/250#) ASA Standard. Suction and Discharge are on a common centerline in both the horizontal and vertical planes.

Impeller - The impeller is an enclosed double-suction type made of bronze, ductile iron, or 316 stainless steel and statically and hydraulically balanced. The impeller is keyed to the shaft and positioned axially by the shaft sleeves. Hub has sufficient metal thickness to allow machining for installation of impeller rings.

Shaft - The shaft is made of AISI 4140, 316 stainless steel, or 17-4 ph and is large enough to operate under load with minimum deflection.

Shaft Sleeves - The shaft sleeves are made of bronze, 420 hardened stainless steel (packing only), 316 stainless steel, or cast iron and protect the shaft from wear and from contact with the pumped liquid. An O-ring is furnished under sleeve to prevent leakage.

Stuffing Box - The stuffing box consists of at least six (6) rings of die formed, graphite acrylic yarn packing and a split type gland to permit removal and access to packing. Ample space is provided for repacking the stuffing box. Arrangement provides for field or factory conversion to mechanical seals without machine work.

Casing Rings - The casing rings are made of bronze, cast iron, or Nitronic 60 stainless steel and are installed with an anti-rotation device.

Bearings - The bearings are grease lubricated or oil lubricated. The inboard or coupling end bearing is a single row ball bearing. The outboard bearing is a double row cylindrical roller bearing which is retained by bearing locknut and lockwasher.

Bearing Housings - The bearing housings are bolted to the end of the lower half casing and assure positive alignment of the rotating element. The housings provide a fit for the inboard bearing that allows freedom for thermal expansion while the outboard bearing is clamped in place to take all thrust loads and keep the rotating element in its proper axial location.

Baseplate - The baseplate is sufficiently rigid to support the pump and driver. The baseplate is steel with a drip pan beneath the pump end. The drip pan contains a tapped drain connection.

Coupling - Coupling is an all metal type.

Coupling Guard - The coupling guard is all metal.

Rotation - Pump has clockwise or counterclockwise rotation when viewed from its driven end.

NAMEPLATE INFORMATION

Every pump has an A-C Pump nameplate that provides information about the pump. The nameplate is located on the pump casing.

Special tags which provide additional information (mechanical seal data, etc.) and special tagging required by customers are located on the pump casing or on the bearing frame.

The standard nameplate (Fig. 1) provides information about the pump size, type, serial number, rated head, capacity, speed, impeller diameter, model number, and maximum field hydrostatic test pressure.

The identification No. is a number which the end user of the pump requests to be put on the nameplate to identify the pump in his operation.

The year indicates the year in which the pump was built.

Rating and hydrostatic test pressure are expressed in English units. Note the format of pump size: Suction x Discharge x Nominal Impeller Diameter in inches, for example, 10x6x22.

The frame plate provides information concerning the bearings and their lubrication. The inboard and outboard bearing numbers refer to the bearing manufacturer's numbers.

When ordering spare parts you will need to identify pump model, size, serial number, and the catalog number of required parts. Pump information can be taken from the A-C Pump nameplate. Catalog numbers can be found in this manual.

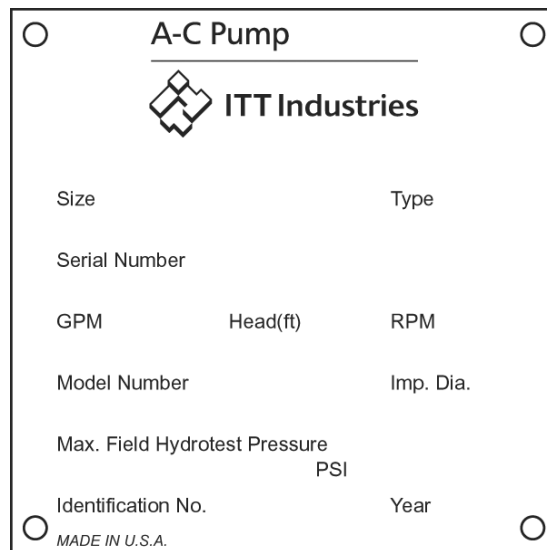

Fig. 1

INSTALLATION

RECEIVING THE PUMP	13
LIFTING THE PUMP	13
STORAGE	15
LOCATION	15
FOUNDATION	16
SETTING THE BASEPLATE	16
Grouting Procedure	17
ALIGNMENT PROCEDURE	17
DOWELING	19
SUCTION AND DISCHARGE PIPING	19
Suction Piping	19
Discharge Piping.	21
Pressure Gauges	21
STUFFING BOX LUBRICATION	22
Packing	22
Mechanical Seals	23
Cartridge Seals.	23
Cyclone Separator	23



Equipment that will operate in a potentially explosive environment must be installed in accordance with the following instructions.

RECEIVING THE PUMP

Check pump for shortages and damage immediately upon arrival (an absolute must!). Prompt reporting to the carrier's agent, with notations made on the freight bill, will expedite satisfactory adjustment by the carrier.

Pumps and drivers are normally shipped from the factory mounted on a baseplate. Couplings may either be

completely assembled or have the coupling hubs mounted on the shafts and the connecting members removed. When the connecting members are removed, they will be packaged in a separate container and shipped with the pump or attached to the baseplate.

LIFTING THE PUMP

The following instructions are for the safe lifting of your pump.

The unit should be unloaded and handled by lifting equally at four or more points on the baseplate. The lugs on the upper half casing are designed for lifting the upper half casing only.

HORIZONTAL

Bare Pump

1. Using a nylon sling, chain, or wire rope, hitch around both bearing housings. (See Fig. 2)

Pump, Base, and Driver

2. Care must be taken to size equipment for unbalanced loads which may exist if the driver is not mounted on

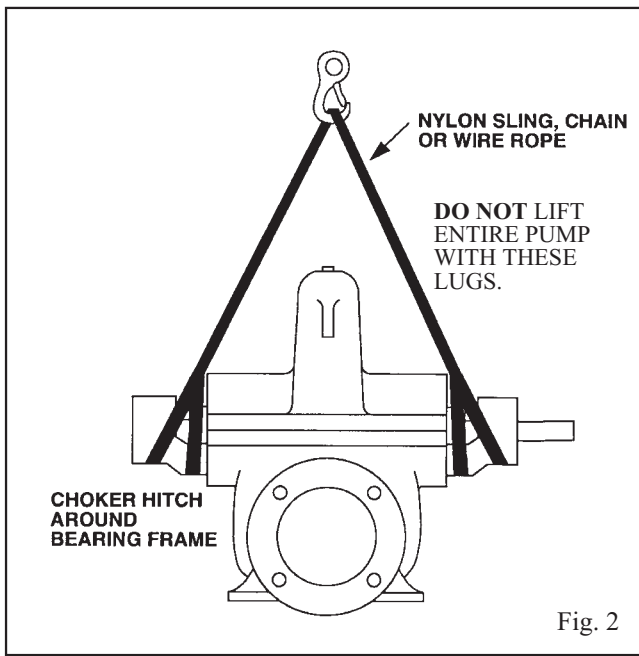

Fig. 2

the base at the time of lifting. Driver may or may not be mounted at the factory.

3. Pump, base, and driver assemblies where the base length exceeds 100 inches may not be safe to lift as a complete assembly. Damage to the baseplate may occur. If the driver has been mounted on the baseplate at the factory, it is safe to lift the entire assembly. If driver has not been mounted at the factory and the overall baseplate length exceeds 100 inches, do not lift entire assembly consisting of pump, base, and driver. Instead, lift the pump and baseplate to its final location without the driver. Then mount the driver.

Bases supplied with lifting holes

Large bases are supplied with lifting holes in the sides or the ends of the base. (See Fig. 3)

Using ANSI/OSHA Standard “S” hooks, place the “S” hooks in the holes provided in the four corners of the base. Be sure the points of the hooks do not touch the bottom of the pump base. Attach nylon slings, chains, or wire rope to

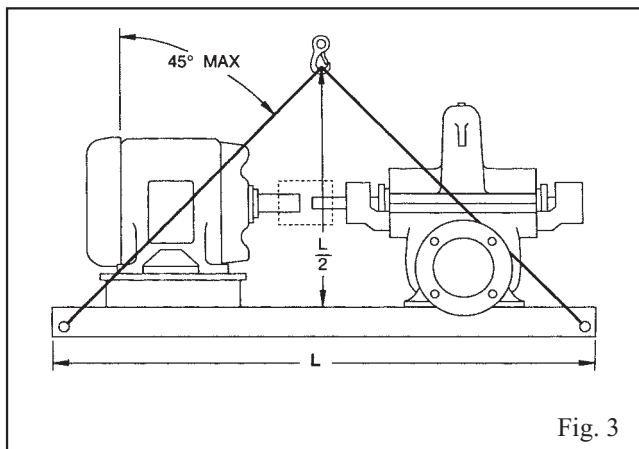

Fig. 3

the “S” hooks. Size the equipment for the load so the lift angle will be less than 45° from the vertical.

Bases supplied without lifting holes

Place one sling around the outboard bearing housing.

WARNING
Do not use lugs on top half of casing.

Place the remaining sling around the back end of the driver as close to the mounting feet as possible. Make certain sling will not damage housing cover or conduit boxes.

Join the free ends of the slings together and place over the lifting hook. Use extreme care when positioning sling under the driver so it cannot slip off. (See Fig. 4)

VERTICAL

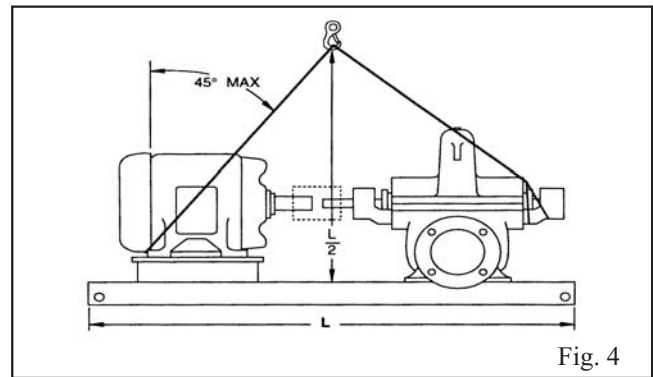

Fig. 4

Half Pedestal

1. Place nylon sling chain or wire rope around both flanges. Use a latch hook or standard shackle and end loops.

Be sure the lifting equipment is of sufficient length to keep the lift angle less than 30° from the vertical. (See Fig. 5)

Full Pedestal

2. Install eyebolts in the three holes provided at the top of the support, being sure to tighten securely. Attach chain or wire rope using latch hook or standard shackle and end loop.

Be sure to use shoulder eyebolts that are manufactured per ANSI B18.15 and sized to fit the holes provided.

Be sure lifting equipment is of sufficient length to keep the lift angle less than 30° from the vertical. (See Fig. 6)

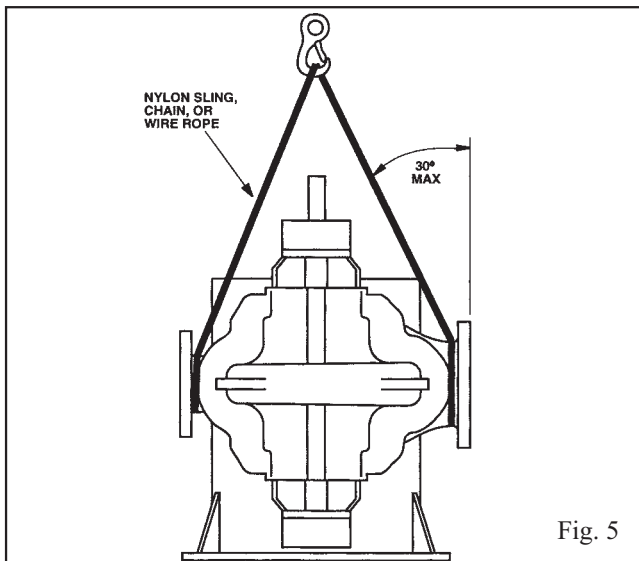

Fig. 5

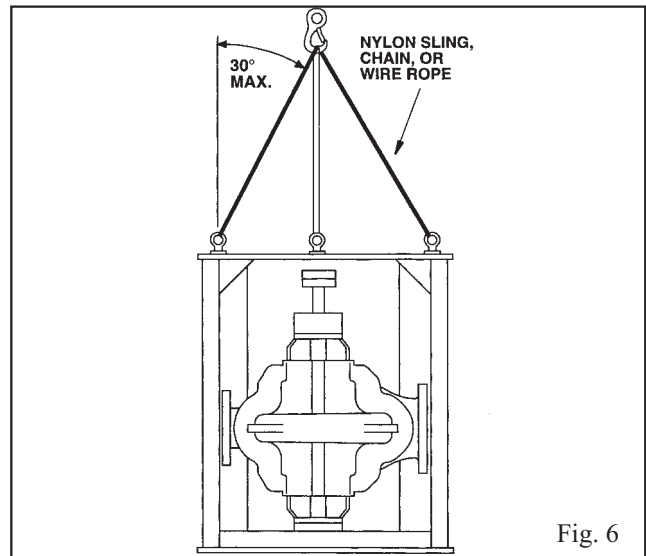

Fig. 6

STORAGE

The following storage procedures apply to the pump only. Other accessories such as motors, steam turbines, gears, etc., must be handled per the respective manufacturer's recommendations.

TEMPORARY

Temporary storage is considered one month or less. If the pump is not to be installed and operated soon after arrival, store it in a clean, dry place having slow, moderate changes in ambient temperature. Rotate the shaft periodically to coat the bearings with lubricant and to retard oxidation, corrosion, and to reduce the possibility of false brinelling of the bearings. Shaft extensions and other exposed machine surfaces should be coated with an easily removable rust preventative such as Ashland Oil Tectyl No. 502C.

For oil lubricated bearings, fill the frame completely with oil. Before putting equipment into operation, drain the oil and refill to proper level.

LONG TERM

Storage longer than one month is considered long term storage. Follow the same procedure for temporary storage with the following addition. Add one half ounce of a corrosion inhibiting concentrated oil such as Cortec Corp. VCI-329 (for both grease and oil lubricated bearings). Seal all vents and apply a water proof tape around the oil seals in the bearing frame. Remember for oil lubricated bearings to drain the oil from the frame and refill to the proper level before running pump.

LOCATION

The pump should be installed as near the suction supply as possible, with the shortest and most direct suction pipe practical. The total dynamic suction lift (static lift plus friction losses in suction line) should not exceed the limits for which the pump was sold.

The pump must be primed before starting. Whenever possible, the pump should be located below the fluid level to facilitate priming and assure a steady flow of liquid. This condition provides a positive suction head on the pump. It is also possible to prime the pump by pressurizing the suction vessel.

When installing the pump, consider its location in relation to the system to assure that sufficient Net Positive Suction Head (NPSHA) is available at the pump inlet connection.

Available NPSH must always equal or exceed the required NPSH (NPSHR) of the pump.

The pump should be installed with sufficient accessibility for inspection and maintenance. A clear space with ample head room should be allowed for the use of an overhead crane or hoist sufficiently strong to lift the unit.

NOTE: Allow sufficient space to be able to dismantle pump without disturbing the pump inlet and discharge piping.

Select a dry place above the floor level wherever possible. Take care to prevent pump from freezing during cold weather when not in operation. Should the possibility of freezing exist during a

shut-down period, the pump should be completely drained, and all passages and pockets where liquid might collect should be blown out with compressed air.

Make sure there is a suitable power source available for the pump driver. If motor driven, the electrical characteristics of the power source should be identical to those shown on motor data plate.

FOUNDATION

The foundation must be substantial enough to absorb vibration. (*Hydraulic Institute Standards* recommends the foundation weigh at least five [5] times the weight of the pump unit.) It must form a permanent and rigid support for the baseplate. This is important in maintaining the alignment of a flexibly coupled unit.

Foundation bolts of the proper size should be embedded in the concrete to a depth of eight (8) to twelve (12) inches and locked with either a hook around a reinforcing bar or alternatively, a nut and washer at the bottom. The bolts should have a sleeve around them at least six (6) times the bolt diameter in length and at least two (2) bolt sizes larger in I.D. If a nut and washer are used for locking, the washer should have an O.D. two (2) sizes larger than the sleeve. Foundation bolts should be sized .125" less than the anchor bolt holes in the base.

The foundation should be poured to within .75" - 1.5" of the finished height. (See Fig. 7) Freshly poured foundations should be allowed to cure for several days before the unit is set in place and grouted.

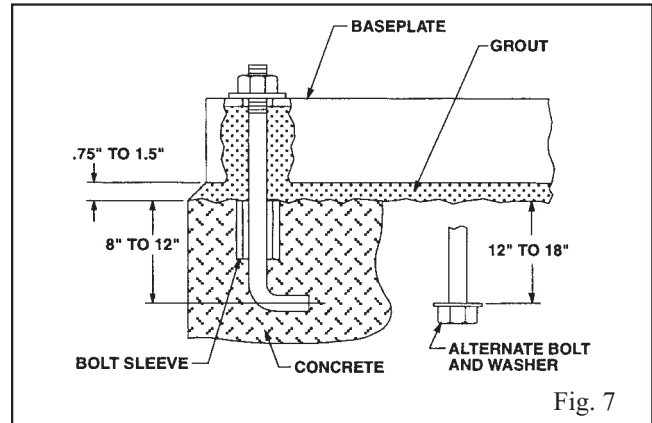

Fig. 7

SETTING THE BASEPLATE

Pump units are checked at the factory for align ability to required tolerances.

Due to flexibility of an ungrouted base and handling in shipment, it should not be assumed that the unit is in alignment when it is placed on the rough foundation.

If these directions are followed, the required alignment should be readily achieved.

Initial or rough alignment must be done prior to grouting of baseplate. Rough alignment is designated as .020" TIR (Total Indicator Reading) parallel alignment and .009" TIR per inch of radius angular alignment (See ALIGNMENT PROCEDURE). Use blocks at anchor bolts and midway between to position bottom of base at finished height (See Fig. 8) with foundation bolts extending through holes in the baseplate. Metal wedges with a small taper may be used in lieu of blocks and shims.

If the unit has a non-flexible coupling (e.g. Falk Gear coupling), the coupling halves should be disconnected; this is generally not necessary on flexible type couplings (e.g. Wood's Sure-Flex coupling).

Tighten up all pump and motor bolts to assure they have not loosened or a "soft foot" has occurred due to base distortion in shipment. A "soft foot" causes a change in the alignment when unloosening one bolt.

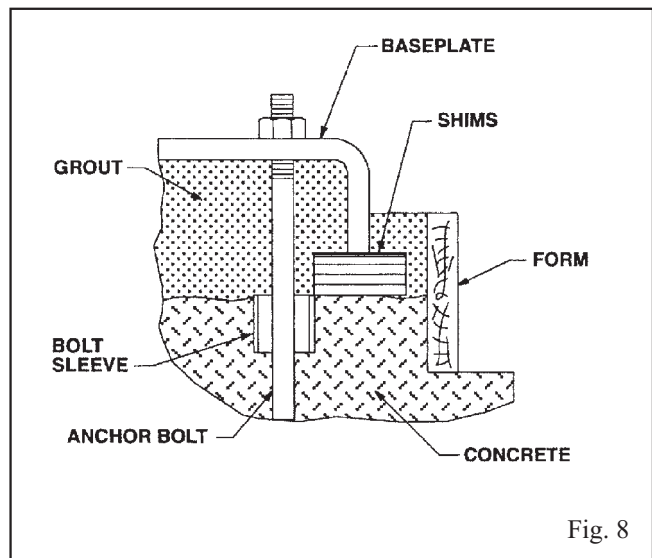

Fig. 8

If the driver is being field installed, it should be centered in its bolt holes with shims added to bring the driver into rough alignment with the pump. (The pump may have to be moved also.)



CAUTION

Do not exceed six (6) shims, using as thick a shim as possible, otherwise “sponginess” or “soft foot” will result. Place thin shims in between thick shims.

Level and plumb the pump shaft, coupling faces and flanges by adding or removing shims between the blocks and the bottom of the base. Hand tighten the anchor bolt nuts at first. Being very careful not to distort the base, snug down the nuts with a wrench. The non-flexible coupling should not be reconnected until the alignment operation has been completed.

NOTE: *The baseplate does not have to be level.*

After foundation bolts are lightly torqued, recheck alignment requirements once more. Follow requirements outlined at the beginning of this section. If alignment must be corrected, add or remove shims or wedges under the baseplate.

The unit can then be grouted. (See Fig. 8)

Grout compensates for the uneven foundation. Together with the baseplate, it makes a very rigid interface between the pump and the foundation distributing the weight over the length of the base and preventing shifting.

Use an approved, non-shrinking grout such as Embeco 636 or 885 by Master Builders, Cleveland, Ohio or equivalent.

GROUTING PROCEDURE

1. Build a strong form around the foundation to contain the grout.
2. Soak the top of the foundation thoroughly, then remove surface water.
3. The baseplate should be completely filled with grout and, if necessary, temporarily use air relief tubing or drill vent holes to remove trapped air.
4. After the grout has thoroughly hardened (approximately 24 hours), tighten the foundation bolts fully.
5. Check the alignment after the foundation bolts are tightened.
6. Approximately fourteen (14) days after the grout has been poured and the grout has thoroughly dried, apply an oil base paint to the exposed edges of the grout to prevent air and moisture from coming in contact with the grout.

3

ALIGNMENT PROCEDURE

Proper rough alignment must be made during unit setting and grouting. See previous section.

There are two forms of misalignment between the pump shaft and the driver shaft as follows:

1. **Angular misalignment** — shafts have axis concentric at intersection, but not parallel.
2. **Parallel offset misalignment** — shafts have axis parallel, but offset.

The necessary tools for checking alignment are: (1) a straight edge and a taper gauge or set of feeler gauges or, (2) a dial indicator with mounting magnet and extension bars.

Check and correct for angular misalignment before correcting parallel alignment. Final alignment should be made by moving and shimming the motor on its base until the coupling hubs are within the recommended tolerances measured in total run out. All measurements

taken with the pump and driver bolts tightened. Final alignment check should be made after the unit has attained its final operating temperature.

Method 1 - Using straight edge and taper gauges or feelers (Fig. 9):

Proceed with this method only if satisfied that face and outside diameters of the coupling halves are square and concentric with the coupling bores. If this condition does not exist or elastomeric couplings do not make this method convenient, use Method 2.

Check for angular alignment by inserting the taper or feeler gauges between the coupling faces at 90° intervals. The unit is in angular alignment when these four (4) measurements are the same, or within recommended tolerances.

Check for parallel alignment by placing a straight edge across both coupling rims on all four sides. The unit is in parallel alignment when the straight edge rests evenly across both coupling rims in all four (4) positions.

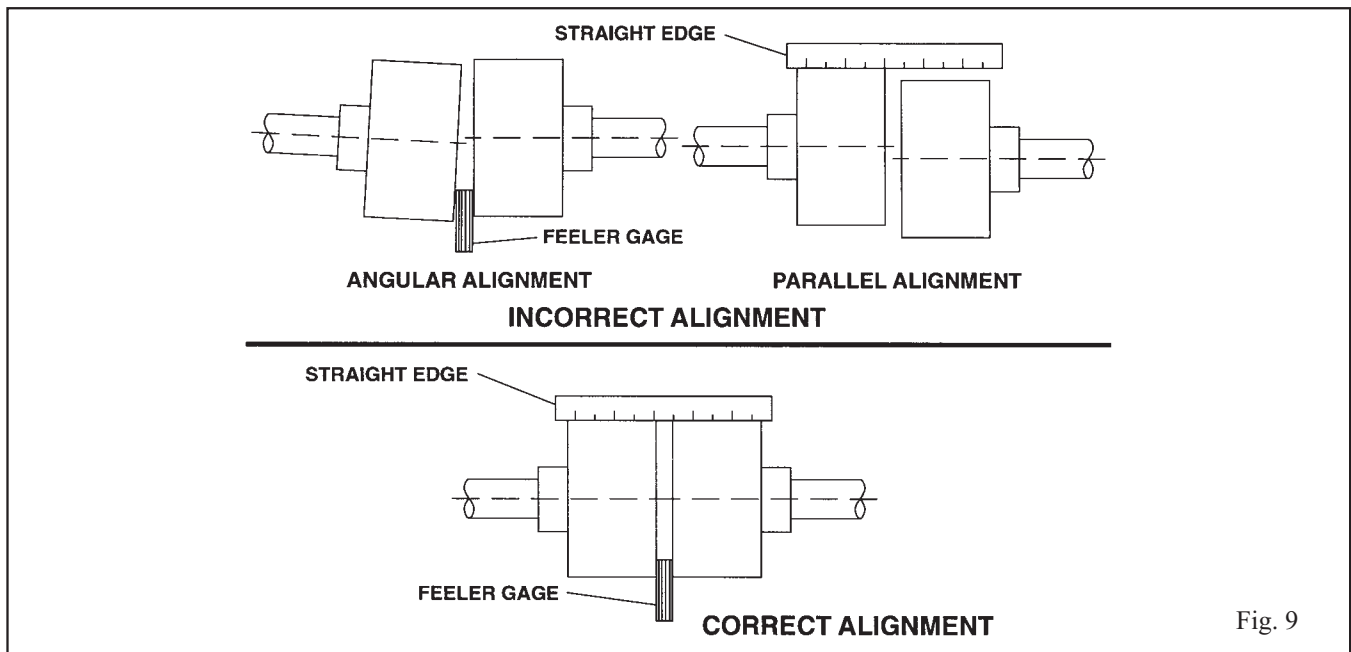

Fig. 9

Method 2 - Dial Indicators (Fig. 10):

A dial indicator can be used to attain more accurate alignment.

Fasten the indicator stand or magnetic base to the pump half of the coupling and adjust the assembly until the indicator button is resting on the other half coupling periphery.

Set the dial to zero and chalk mark the coupling half where the button rests. Also place a separator between the coupling halves so bearing slack does not affect the readings. (Chalk and separators are not necessary on the elastomeric couplings that have not been disconnected.) Rotate both shafts by the same amount; i.e., all readings must be made with the button on the chalk mark.

The dial readings will indicate whether the driver has to be raised, lowered or moved to either side. Accurate alignment of shaft centers can be obtained with this method even where faces or outside diameters of the coupling are not square or concentric with the bores. After each adjustment, recheck both parallel and angular alignments.

***NOTE:** Gross deviations in squareness or concentricity may cause rotation unbalance problems and if so must be corrected.*

PERMISSIBLE COUPLING MISALIGNMENT
Per coupling manufacturer's acceptable misalignment limits.

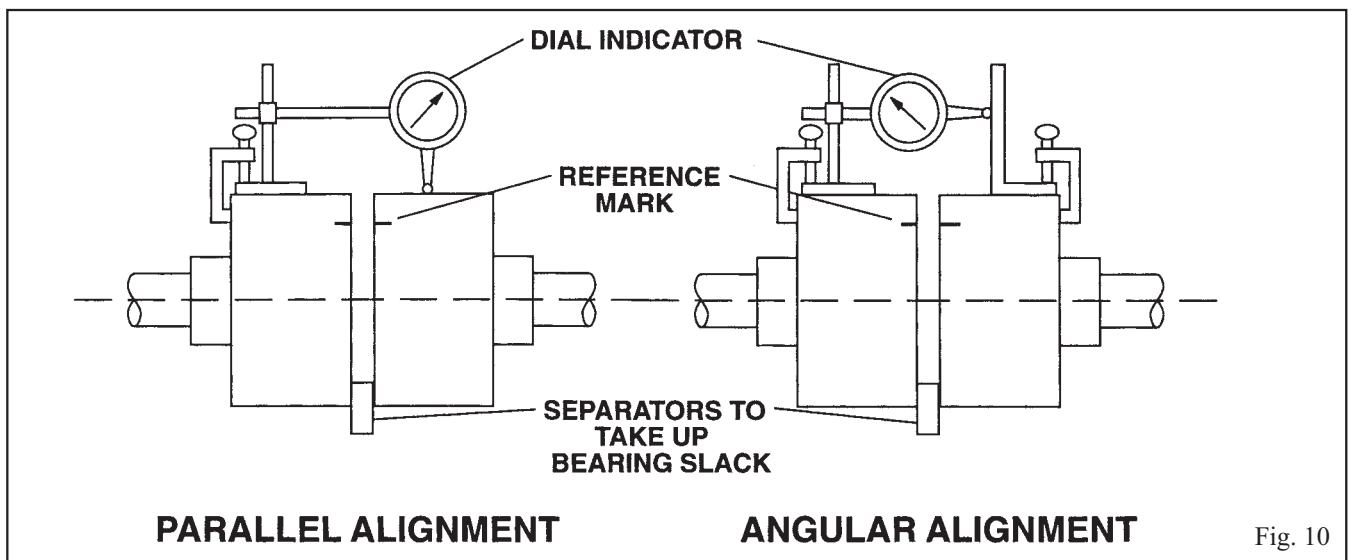

Fig. 10

DOWELING

Pump units may, if desired, (or required in specification) be doweled on diagonally opposite feet. This should not be

done until the unit has been run for a sufficient length of time and alignment is within the above alignment tolerance.

SUCTION AND DISCHARGE PIPING

The introduction of pumpage into a piping system which is not well designed or adjusted may cause strain on the pump, leading to misalignment or even impeller rubbing. Since slight strain may go unnoticed, final alignment should be done with the system full and up to final temperature.

Pipe flanges should not impose any strain on the pump. This can be checked by a dial indicator. Any strain must be corrected by adjustments in the piping system.

When installing the pump piping, be sure to observe the following precautions:

Piping should always be run to the pump.

Do not move the pump to pipe. This could make final alignment impossible.

Both the suction and discharge piping should be independently anchored near the pump and properly aligned so that no strain is transmitted to the pump when the flange bolts are tightened. Use pipe hangers or other supports at necessary intervals to provide support. When expansion joints are used in the piping system they must be installed beyond the piping supports closest to the pump. Tie bolts and spacer sleeves should be used with expansion joints to prevent pipe strain. Do not install expansion joints next to the pump or in any way that would cause a strain on the pump resulting from system pressure changes. When using rubber expansion joints, follow the recommendations of the *Technical Handbook on Rubber Expansion Joints and Flexible Pipe Connectors*. It is usually advisable to increase the size of both suction and discharge pipes at the pump connections to decrease the loss of head from friction.

Install piping as straight as possible, avoiding unnecessary bends. Where necessary, use 45° or long radius 90° fittings to decrease friction losses.

Make sure that all piping joints are air-tight.

Where flanged joints are used, assure that inside diameters match properly.

Remove burrs and sharp edges when making up joints.

Do not “spring” piping when making any connections.

Provide for pipe expansion when hot fluids are to be pumped.

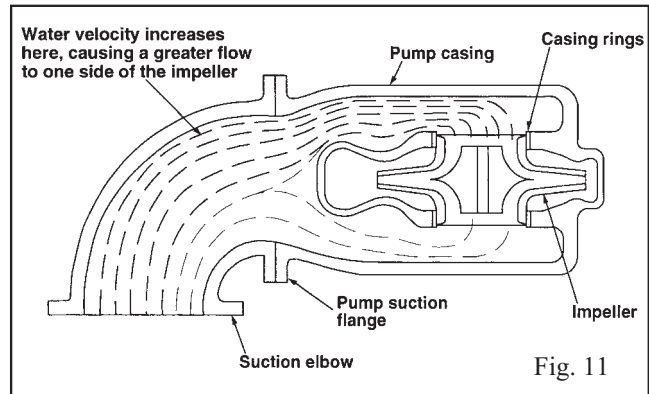

3

SUCTION PIPING

When installing the suction piping, observe the following precautions. (See Fig. 12)

The sizing and installation of the suction piping is extremely important. It must be selected and installed so that pressure losses are minimized and sufficient liquid will flow into the pump when started and operated.

Many NPSH (Net Positive Suction Head) problems can be directly attributed to improper suction piping systems.

Suction piping should be short in length, as direct as possible, and never smaller in diameter than the pump suction opening. A minimum of five (5) pipe diameters between any elbow or tee and the pump should be allowed. If a long suction pipe is required, it should be one or two sizes larger than the suction opening, depending on its length.



CAUTION

An elbow should not be used directly before the suction of a double suction pump if its plane is parallel to the pump shaft. This can cause an excessive axial load or NPSH problems in the pump due to an uneven flow distribution. (See Fig. 11) If there is no other choice, the elbow should have straightening vanes to help evenly distribute the flow.

Eccentric reducers should be limited to one pipe size reduction each to avoid excessive turbulence and noise. They should be of the conical type. Contour reducers are not recommended.

When operating on a suction lift, the suction pipe should slope upward to the pump nozzle. A horizontal suction line must have a gradual rise to the pump. Any high point in the pipe can become filled with air and prevent proper operation of the pump. When reducing the piping to the suction opening diameter, use an eccentric reducer with the eccentric side down to avoid air pockets.

NOTE: When operating on suction lift never use a concentric reducer in a horizontal suction line, as it tends to form an air pocket in the top of the reducer and the pipe.

Fig. 12 shows some correct and incorrect suction piping arrangements.

When installing valves in the suction piping, observe the following precautions:

1. If the pump is operating under static suction lift conditions, a foot valve may be installed in the suction line to avoid the necessity of priming each time the pump is started. This valve should be of the flapper type, rather than the multiple spring type, sized to avoid excessive friction in the suction line. (Under all other conditions, a check valve, if used, should be installed in the discharge line. See Discharge Piping.)
2. When foot valves are used, or where there are other possibilities of “water hammer,” close the discharge valve slowly before shutting down the pump.
3. Where two or more pumps are connected to the same suction line, install gate valves so that any pump can be isolated from the line. Gate valves should be installed on the suction side of all pumps with a positive pressure for maintenance purposes. Install gate valves with stems horizontal to avoid air pockets. Globe valves should not be used, particularly where NPSH is critical.
4. The pump must never be throttled by the use of a valve on the suction side of the pump. Suction valves should be used only to isolate the pump for maintenance purposes, and should always be installed in positions to avoid air pockets.

DISCHARGE PIPING

If the discharge piping is short, the pipe diameter can be the same as the discharge opening. If the piping is long, the pipe diameter should be one or two sizes larger than the discharge opening. On long horizontal runs, it is desirable to maintain as even a grade as possible. Avoid high spots, such as loops, which will collect air and throttle the system or lead to erratic pumping.

A check valve and an isolating gate valve should be installed in the discharge line. The check valve, placed between pump and gate valve, protects the pump from excessive back pressure, and prevents liquid from running back through the pump in case of power failure. The gate valve is used in priming and starting, and when shutting the pump down.

PRESSURE GAUGES

Properly sized pressure gauges should be installed in both the suction and discharge nozzles in the gauge taps provided. The gauges will enable the operator to easily observe the operation of the pump, and also determine if the pump is operating in conformance with the performance curve. If cavitation, vapor binding, or other unstable operation should occur, widely fluctuating discharge pressure will be noted.

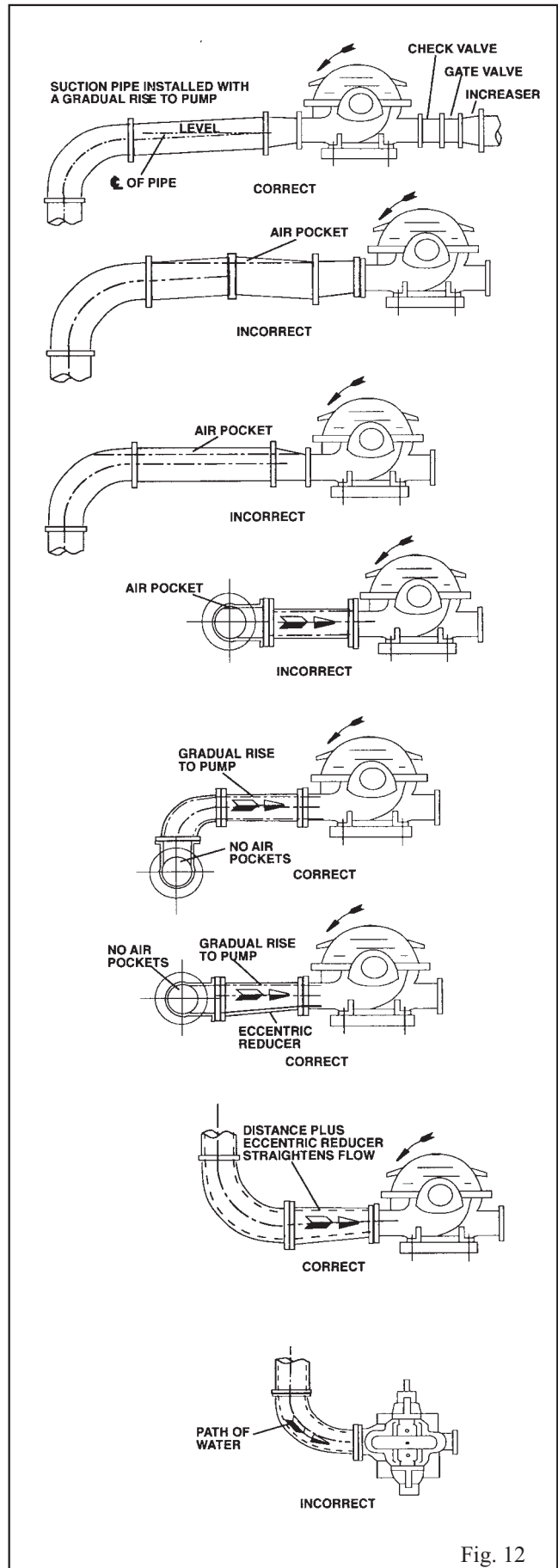

Fig. 12

STUFFING BOX LUBRICATION

Contaminants in the pumped liquid must not enter the stuffing box. These contaminants may cause severe abrasion or corrosion of the shaft, or shaft sleeve, and rapid packing or mechanical seal deterioration; they can even plug the stuffing box flushing and lubrication system. The stuffing box must be supplied at all times with a source of clean, clear liquid to flush and lubricate the packing or seal. The most important consideration is to establish the optimum flushing pressure that will keep contaminants from the stuffing box cavity. If this pressure is too low, fluid being pumped may enter the stuffing box. If the pressure is too high, excessive packing or seal wear may result; and extreme heat may develop in the shaft causing higher bearing temperatures. The most desirable condition, therefore, is to use a seal water pressure 15-20 psig above the maximum stuffing box pressure.

If the pump system pressure conditions vary, packing adjustment becomes difficult. Consideration should be given to using a mechanical seal. (See Mechanical Seals.)

PACKING

Standard pumps are normally shipped with the packing set loose (not installed). If the pump is installed within 60 days after shipment, the packing will be in good condition with a sufficient supply of lubrication. If the pump is stored for a longer period, it may be necessary to replace the factory supplied packing set. In all cases, however, inspect the packing before it is installed and the pump started.

NOTE: Packing adjustment is covered in the MAINTENANCE SECTION of this manual.

On some applications, it is possible to use internal liquid lubrication (pumped liquid) to lubricate packing. Only when all of the conditions prevail, can this be done:

1. Liquid is clean, free from sediment and chemical precipitation and is compatible with seal materials.
2. Temperature is above 32° F and below 160° F.
3. Suction pressure is below 75 psig.
4. Lubrication (pumped liquid) has lubricating qualities.
5. Liquid is non-toxic and non-volatile.

When the liquid being pumped contains solids or is otherwise not compatible with packing materials, an outside supply of seal liquid should be furnished. In general, external-injection liquid (from an outside source) is required when any of the above conditions cannot be met.

The standard stuffing box consists of six (6) rings of packing and a split type gland. A shaft sleeve which extends through the box and under the gland is provided to protect the shaft.

A tapped hole is supplied in the stuffing box directly over the seal cage to introduce a clean, clear sealing medium. The stuffing box must, at all times, be supplied with sealing liquid at a high enough pressure to keep the box free from foreign matter, which would quickly destroy the packing and score the shaft sleeve.

Only a sufficient volume of sealing liquid to create a definite direction of flow from the stuffing box inward to the pump casing is required, but the pressure is important. Apply seal water at a rate of approximately .25 GPM at a pressure approximately 15 to 20 psig above the suction pressure. (Approximately one [1] drop per second.)

One recommended method to minimize error in regulating flushing water is a "Controlled Pressure System." (Fig. 13) Most important is the pressure reducing valve adjusted to a value slightly exceeding the maximum stuffing box operating pressure (assuming it is reasonably constant). A flow indicating device will serve to indicate a failing of the bottom packing rings allowing leakage in the pump.

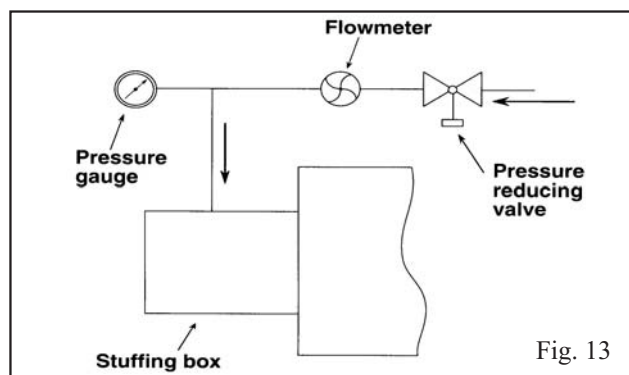

External sealing liquid should be adjusted to the point where the packing runs only slightly warm, with a very slow drip from the stuffing box. Excess pressure from an external source can be very destructive to packing. More pressure is required, however, for abrasive slurries than for clear liquids. Examination of the leakage will indicate whether to increase or decrease external pressure. If slurry is present in the leakage, increase the pressure until only clear liquid drips from the box. If the drippage is corrosive or harmful to personnel, it should be collected and piped away.

A common error is to open the external piping valve wide and then control the drippage by tightening the packing gland. Actually, a combination of both adjustments is essential to arrive at the optimum condition. The life of packing and sleeve depends on this careful control more than any other factor.

MECHANICAL SEALS

Mechanical seals are preferred over packing on some applications because of better sealing qualities and longer serviceability. Leakage is eliminated when a seal is properly installed, and normal life is much greater than that of packing on similar applications. A mechanical shaft seal is supplied in place of a packed stuffing box when specifically requested. The change from packing to an alternate arrangement may be made in the field by competent service personnel. Conversion parts may be ordered from your A-C Pump Sales Representative.

Just as with packing, the mechanical seal chamber must be supplied, at all times, with a source of clean, clear liquid to flush and lubricate the seal. The most important consideration is to establish the optimum flushing pressure that will keep contaminants from the seal cavity. If this pressure is too low, fluid being pumped may enter the stuffing box. If the pressure is too high, excessive seal wear may result.

When contaminants are present in the pumpage, an external source of clean seal water must be supplied. Supply approximately .25 GPM at a pressure approximately 15 to 20 psig above the suction pressure.

Fig. 13 shows the recommended “Controlled Pressure System” for a mechanical seal. Seal water enters the seal chamber, lubricates the seal face, and exits into the pump itself. Positive flow in the seal water line indicates adequate seal water pressure.

CARTRIDGE SEALS

Follow the appropriate lubrication directions for mechanical seals given in this section. Most cartridge seals provide flushing connections on their glands. Use the cartridge seal gland flushing taps (if provided) for your seal water connections instead of the stuffing box tap. The quench taps on the glands (if present) are normally only used in chemical applications. Consult seal manufacturer’s literature for more detailed information.

CYCLONE SEPARATOR

If the fluid being pumped contains sediment and there is no external, clean water source available to flush the mechanical seals, a cyclone separator can be used to remove most of the sediment from the liquid being pumped so it can be used to flush the seals. The separator is placed in the seal water piping line and removes the sediment to an external drain (normally back to the pump suction line).

OPERATION

PRE-START CHECKS	25
PRIMING	25
Flushing	25
Filling	25
STARTING	26
OPERATIONAL CHECKLIST	26
SHUTDOWN	27
FREEZE PROTECTION	27
FIELD TESTS	27

PRE-START CHECKS

Before the initial start of the pump, make the following inspections:

1. Check alignment between pump and driver. See the section on alignment for alignment requirements.
2. Check all connections to motor and starting device with wiring diagram. Check voltage, phase, and frequency on motor nameplate with line circuit.
3. Check suction and discharge piping and pressure gauges for proper operation.
4. Turn rotating element by hand to assure that it rotates freely.
5. Check stuffing box adjustment, lubrication, and piping.
6. Check driver lubrication.
7. Assure that pump bearings are properly lubricated.
8. Assure that coupling is properly lubricated, if required.
9. Assure that pump is full of liquid and all valves are properly set and operational, with the discharge valve and the suction valve open. Purge all air from top of casing.
10. Check rotation. Be sure that the driver operates in the direction indicated by the arrow on the pump casing as serious damage can result if the pump is operated with incorrect rotation. Check rotation each time the motor leads have been disconnected.

PRIMING

If the pump is installed with a positive head on the suction, it can be primed by opening the suction valve, and loosening the vent plug on the top of the casing (Do not remove), allowing air to be purged from the casing.

If the pump is installed with a suction lift, priming must be done by other methods such as foot valves, ejectors, or by manually filling the casing and suction line.



CAUTION

Under either condition, the pump must be completely filled with liquid before starting. The pump must not be run dry in the hope it will prime itself. Serious damage to the pump may result if it is started dry.

FLUSHING

New and old systems should be flushed to eliminate all foreign matter. Heavy scale, welding splatter and wire or other large foreign matter can clog the pump impeller. This will reduce the capacity of the pump causing cavitation, excessive vibration, and/or damage to close clearance parts (wear rings, seals, sleeves, etc.)

FILLING

Vents should be located at the highest point so entrained gases and air can escape. However, if the gases are flammable, toxic, or corrosive they should be vented to an appropriate place to prevent harm to personnel or other parts of the system. Pipe hangers

and anchors should be checked to make sure they are properly set to take the additional weight of the pumpage.

All drains should be closed when filling the system. Filling should be done slowly so that excessive velocities do not cause rotation of the pumping elements which may cause damage to the pump or its driver. The adequacy of the anchors

and hangers may be checked by mounting a dial indicator off of any rigid structure not tied to the piping and setting the indicator button on the pump flange in the axial direction of the nozzle. If the indicator moves, as the filling proceeds, the anchors and supports are not adequate or set properly and should be corrected.

STARTING

1. Close drain valves.
 2. Open fully all valves in the suction and discharge lines.
 3. Turn on seal water to the stuffing box. (If pumped fluid is dirty or if leaking of air is to be prevented, these lines should be always left open.)
 4. Prime the pump.
- NOTE: If the pump does not prime properly, or loses prime during start-up, it should be shutdown and the condition corrected before the procedure is repeated.*
5. Start the pump driver (turbines and engines may require warming up; consult the manufacturer's instructions).
 6. When the pump is operating at full speed, check to see that the check valve has opened up. Check valve must open 5 seconds or less after start-up to prevent damage to pump by operating at zero flow.
 7. Adjust the liquid seal valves to produce the recommended pressure for either the mechanical seal or packed stuffing box.

OPERATIONAL CHECKLIST

- 1. Driver/Pump Rotation**
Check rotation each time the motor leads have been disconnected. Be sure that the driver operates in the direction indicated by the arrow on the pump casing. Rough operation and extreme vibration can result if the pump is operated in the wrong direction.
 - 2. Stuffing Box Adjustment**
Make stuffing box packing gland and lubrication adjustments.
 - 3. Flow**
An accurate measurement of flow rate (volume/time) is difficult in the field. Venturi meters, flow nozzles, orifice plates, or timing the draw down in the wet well are all possible methods. Record any reading for future reference.
 - 4. Pressure**
Check and record both suction and discharge pressure gauge readings for future reference. Also, record voltage, amperage per phase, kilowatts if an indicating wattmeter is available, and pump speed.
 - 5. Temperature**
Check and record bearing temperatures using a thermometer. Temperature should not exceed 180° F.
- NOTE: Just because bearing housings are too hot to touch does not mean that they are running too hot for proper operation.*
- 6. Vibration and Sound**
The acceptable vibration level of a centrifugal pump depends on the rigidity of the pump and the supporting structure. Recommended values for vibration can vary between .20 ips (inches per second) velocity to .60 ips velocity depending on the operating characteristics and the structure. Refer to the Centrifugal Pump section of the *Hydraulic Institute Standards* for a complete description and charts on various pumps.

Field sound levels are difficult to measure because of background noise from piping, valves, drivers, gears, etc. Follow recommendations in the *Hydraulic Institute Standards*.

SHUTDOWN

The following steps will take care of most normal shutdowns of the pump, i.e. maintenance. Make any further adjustments of process piping, valves, etc., as required. If the pump is to be removed from service for an extended period of time, refer to the sections on storage and freeze protection.

1. Shut down the driver. (Consult manufacturer's instructions for special operations.)
2. Close suction and discharge valves.
3. Close seal liquid valves. (If pumped liquid is dirty, or if leakage is to be prevented, these lines should always be left open, except when the pump is completely drained.)
4. Open drain valves as required.

FREEZE PROTECTION

Pumps that are shut down during freezing conditions should be protected by one of the following methods.

1. Drain the pump; remove all liquid from the casing.
2. Keep fluid moving in the pump and insulate or heat the pump to prevent freezing.



CAUTION

If heat is used to keep the pump from freezing, do not let the temperature rise above 150° F.

4

FIELD TESTS

A typical performance curve for a specific pump can be obtained from A-C Pump. This can be used in conjunction with a field test, if one is required. A-C Pump tests and curves are based on the *Hydraulic Institute Standards*. Any field test must be conducted according to these Standards.

Unless otherwise specifically agreed, all capacity, head, and efficiencies are based on shop tests when handling clear, cold, fresh water at a temperature not over 85° F.

The Appendices contains a field test report sheet and some useful equations which can be used when conducting a field test.

PREVENTIVE MAINTENANCE

GENERAL MAINTENANCE AND PERIODIC INSPECTION	29
MAINTENANCE TIMETABLE	29
Every Month	29
Every 3 Months	29
Every 6 Months	29
Every Year	30
MAINTENANCE OF FLOOD DAMAGED PUMPS	30
LUBRICATION	30
SEALING INFORMATION.	32
Packing (Non-Asbestos)	32
Mechanical Seals	32
TROUBLESHOOTING	35

GENERAL MAINTENANCE and PERIODIC INSPECTION

Operating conditions vary so widely that to recommend one schedule of preventive maintenance for all centrifugal pumps is not possible. Yet, some sort of regular inspection must be planned and followed. We suggest a permanent record be kept of the periodic inspections and maintenance performed on your pump. This recognition of maintenance procedure will keep your pump in good working condition and prevent costly breakdowns.

One of the best results to follow in the proper maintenance of your centrifugal pump is to keep a record of actual

operating hours. Then, after a predetermined period of operation has elapsed, the pump should be given a thorough inspection. The length of this operating period will vary with different applications, and can only be determined from experience. New equipment, however, should be examined after a relatively short period of operation. The next inspection period can be lengthened somewhat. This system can be followed until a maximum period of operation is reached which should be considered the operating schedule between inspections.

MAINTENANCE TIME TABLE

EVERY MONTH

Check bearing temperature with a thermometer, not by hand. If bearings are running hot (over 180° F), it may be the result of too much or too little lubricant. If changing the lubricant and/or adjusting to proper level does not correct the condition, disassemble and inspect the bearings. Lip seals bearing on the shaft may also cause the housing to run hot. Lubricate lip seals to correct this condition.

EVERY 3 MONTHS

Check the oil on oil lubricated units. Check grease lubricated bearings for saponification. This condition is usually caused by the infiltration of water or other fluid past the bearing shaft seals and can be noticed immediately upon inspection, since it gives the grease a whitish color. Wash out the bearings with a clean industrial solvent and replace the grease with the proper type as recommended.

EVERY 6 MONTHS

Check the packing and replace if necessary. Use the grade recommended. Be sure the seal cages are centered in the stuffing box at the entrance of the stuffing box piping connection.

Take vibration readings on the bearing housings. Compare the readings with the last set of readings to check for possible pump component failure (e.g. bearings).

Check shaft or shaft sleeve for scoring. Scoring accelerates packing wear.

Check alignment of pump and driver. Shim up units if necessary. If misalignment reoccurs frequently, inspect the entire piping system. Unbolt piping at suction and discharge flanges to see if it springs away, thereby indicating strain on the casing. Inspect all piping supports for soundness and effective support of load. Correct as necessary.

EVERY YEAR

Remove the upper half of the casing. Inspect the pump thoroughly for wear, and order replacement parts if necessary.

Check wear ring clearances. Replace when clearances become three (3) times their normal clearance or when a significant decrease in discharge pressure for the same flow rate is observed.

See Engineering Data Section in the Appendix for standard clearances.

Remove any deposit or scaling. Clean out stuffing box piping.

Measure total dynamic suction and discharge head as a test of pump performance and pipe condition. Record the figures and compare them with the figures of the last test. This is important, especially where the fluid being pumped tends to form a deposit on internal surfaces. Inspect foot valves and check valves, especially the check valve which safeguards against water hammer when the pump stops.

A faulty foot or check valve will reflect also in poor performance of the pump while in operation.

NOTE: The above time table is based on the assumption that after startup, the unit has been constantly monitored and such a schedule was found to be consistent with operation, as shown by stable readings. Extreme or unusual applications or conditions should be taken into consideration when establishing the maintenance intervals.

MAINTENANCE OF FLOOD DAMAGED PUMPS

The servicing of centrifugal pumps after a flooded condition is a comparatively simple matter under normal conditions.

Bearings are a primary concern on pumping units. First, dismantle the frame, clean and inspect the bearings for any rusted or badly worn surfaces. If bearings are free from rust and wear, reassemble and relubricate them with one of the recommended lubricants. Depending on the length of time the pump has remained in the flooded area, it is unlikely that bearing replacement is necessary; however, in the event that rust or worn surfaces appear, it may be necessary to replace the bearings.

Next, inspect the stuffing box, and clean out any foreign matter that might clog the box. Packing that appears to be worn, or no longer regulates leakage properly should be replaced. Mechanical seals should be cleaned and thoroughly flushed.

Couplings should be dismantled and thoroughly cleaned. Lubricate the coupling with one of the coupling manufacturer's recommended lubricants where required.

Any pump that is properly sealed at all joints and connected to both the suction and discharge should exclude outside liquid. Therefore, it should not be necessary to go beyond the bearings, stuffing box, and coupling when servicing the pump after flood damage.

LUBRICATION

GREASE LUBRICATION OF BEARINGS

Grease lubricated ball bearings are packed with grease at the factory and ordinarily will require no attention before starting, provided the pump has been stored in a clean, dry place prior to its first operation. The bearings should be watched the first hour or so after the pump has been started to see that they are operating properly.

A lithium based NLGI-2 grade grease should be used for lubricating bearings where the ambient temperature is above -20° F. Grease lubricated bearings are packed at the factory with Mobilux EP No. 2 grease. Other recommended greases are Texaco Multifak EP-2 and Shell Alvania EP-2.

Greases made from animal or vegetable oils are not recommended due to the danger of deterioration and forming of acid. Do not use graphite.

In greasing anti-friction bearings, the use of high pressure equipment is not only unnecessary, but is actually undesirable unless used with great care. High pressure may

damage the bearings or seals, cause unnecessary loss of grease, create a danger of overheating due to over greasing, and produce unsightly conditions around the bearing. Excess grease is the most common cause of overheating. Adequate lubrication is assured if the level of grease is maintained at about the capacity of the bearing and 1/3 to 1/2 of the cavity between the bearing and grease fitting. Any greater amount will, as a rule, be discharged by the seal or vent and be wasted.

The importance of proper lubrication cannot be over emphasized. Lubrication frequency depends upon the speed, size and type of bearing, and operating temperature or environmental conditions. Generally, the smaller the bearing and faster the speed, the more frequent the interval for relubrication with grease. It is recommended that a certain amount of grease be added at intervals of three to six months to replace the small quantity of grease lost between grease flushing intervals. For average bearing housing designs, one (1) ounce of grease will be sufficient at these intervals. For larger or smaller bearing housings this amount may have to be adjusted.

Unfortunately, there is not a grease available which will not harden over time and become less suitable for its purpose due to oxidation. Therefore, it is good practice to remove all the old grease about once a year and thoroughly clean the bearings. This should be done during major overhauls. After gaining experience with each individual pump and its operating characteristics, the relubrication and flushing intervals may be adjusted accordingly. Keep good records and add grease at regular intervals. Then adjustments can be made after the first overhaul, if necessary.

PERIODIC ADDITION OF GREASE

Grease lubricated ball bearings are packed with grease at the factory. Store the pump in a clean, dry place prior to its first operation.

If one is uncertain about the amount of grease in a bearing at relubrication intervals, the safe rule is to add grease slowly (one ounce at a time) as the bearing operates (if this is safe). Remember, a ball or roller bearing in most applications is assured of adequate lubrication if the level of grease is maintained at about the capacity of the bearing and 1/3 to 1/2 of the cavity between the bearing and grease fitting. Any greater amount will, as a rule, be discharged by the seals or vent and be wasted. Excess grease is the most common cause of overheating of the bearings. Remove vent plugs for the first 24 hours of operation after regreasing.

BEARING TEMPERATURE

Normally the maximum desirable operating temperature for ball bearings is 180° F. Special designs may have higher limits. Should the temperature of the bearing frame rise above the limit, the pump should be shut down to determine the cause. A bearing frame which feels hot to the touch of the hand is not necessarily running hot. Check with an accurate temperature measuring device to be sure.

OIL LUBRICATION OF BEARINGS

Oil lubrication on 9100 Series pumps is considered optional. Oil lubricated pumps are installed with Trico oilers (See Fig. 14). The oilers keep the oil level in the housings constant at proper level.

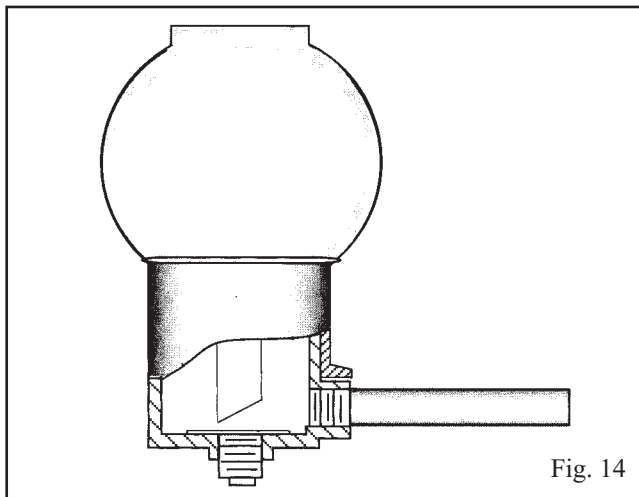

Fig. 14

After the pump has been installed, flush the housing to remove dirt, grit, and other impurities that may have entered the bearing housing during shipment or installation; then refill the housing with proper lubricant. (The housing must be filled using the Trico oiler.) The oil level will be maintained by the Trico oiler. (See the **SERVICE** section for the proper instructions.)

A Mobil Oil, DTE Medium, or equal, meeting the following specification will provide satisfactory lubrication. Similar oils can be furnished by all major oil companies. It is the responsibility of the oil vendor to supply a suitable lubricant.

(1) Saybolt viscosity at 100° F	215 SSU-240 SSU
(2) Saybolt viscosity at 210° F49 SSU
(3) Viscosity index, minimum	95
(4) API gravity28-33
(5) Pour point, maximum	+20° F
(6) Flash point, minimum	400° F
(7) Additives	Rust & Oxidation Inhibitors
(8) ISO viscosity	46

NOTE: Oils from different suppliers should not be mixed. Engine oils are not recommended.

The oil should be a non-foaming, well refined, good grade, straight cut, filtered mineral oil. It must be free from water, sediment, resin, soaps, acid and fillers of any kind.

In installations with moderate temperature changes, low humidity, and a clean atmosphere, the oil should be changed after approximately 1000 hours of operation. The oil should be inspected at this time to determine the operating period before the next oil change. Oil change periods may be increased up to 2000-4000 hours based on an 8000 hour year. Check the oil frequently for moisture, dirt or signs of “breakdown,” especially during the first 1000 hours.



CAUTION

Do not over oil; this causes the bearings to run hot. The maximum desirable bearing housing operating temperature for all ball bearings is 180° F. Should the temperature of the bearing frame exceed 180° F (measured by thermometer) shut down pump to determine the cause.

COUPLING LUBRICATION

Grid or gear tooth couplings (Falk Grid Steelflex or Falk Crowned Tooth coupling for instance) are initially lubricated with Falk Long Term Grease (LTG) and do not require relubrication for up to three years. If coupling leaks grease, or is exposed to extreme temperatures or excessive moisture, more frequent lubrication may be required.

Use coupling manufacturer’s recommended grease to provide trouble free performance.

Flexible couplings (Wood's Sure-Flex or Falk Torus coupling for instance) provide smooth transmission of power. There is no rubbing action of metal against rubber to cause wear. Couplings are not affected by abrasives, dirt or moisture.

This eliminates the need for lubrication or maintenance, and provides clean and quiet performance.

If other types of couplings are used, follow maintenance instructions of coupling manufacturer.

SEALING INFORMATION

PACKING (NON-ASBESTOS)

On packed pumps the packing is installed prior to shipment. All packings used are the highest grade material. Before pump is put into operation check the condition of the packing. If pump is installed within sixty (60) days after shipment the packing will be in good condition with a sufficient supply of lubrication. If pump is stored for a longer period it may be necessary to repack the stuffing box. In all cases, however, we recommend an inspection of the packing before pump is started.

The standard 9100 Series pump packing is made from braided acrylic yarn impregnated with graphite.

A soft, well-lubricated packing reduces stuffing box resistance and prevents excessive wear on the shaft or shaft sleeve. Many brands of packing on the market have the desired qualities. Standard packing is John Crane Style 1340, or equal.

When a pump with fiber packing is first started it is advisable to have the packing slightly loose without causing an air leak. As the pump runs in, gradually tighten the gland bolts evenly. The gland should never be drawn to the point where packing is compressed too tightly and no leakage occurs. This will cause the packing to burn, score the shaft sleeve and prevent liquid from circulating through the stuffing box cooling the packing. The stuffing box is improperly packed or adjusted if friction in the box prevents turning the rotating element by hand. A properly operated stuffing box should run lukewarm with a slow drip of sealing liquid. After the pump has been in operation for some time, and the packing has been in operation for some time, and the packing has been completely run-in, drippage from the stuffing boxes should be at least 40 to 60 drops per minute. This will indicate proper packing and shaft sleeve lubrication and cooling.

NOTE: Eccentricity of the shaft or sleeve through the packing could result in excess leakage that cannot be compensated for. Correction of this defect is very important.

Packing should be checked frequently and replaced as service indicates. Six months might be a reasonable expected life, depending on operating conditions. It is impossible to give any exact predictions. A packing tool should be used to remove all old packing from the stuffing box. Never reuse old and lifeless packing or merely add some new rings. Make sure the stuffing box is thoroughly cleaned before new packing is installed. Also check the condition of the shaft or sleeve for possible scoring or eccentricity, make replacements where necessary.

New packing (non-asbestos) should be placed carefully into the stuffing box. If molded rings are used, the rings should be opened sideways and the joints pushed into the stuffing box first. The rings are installed one at a time, each ring seated firmly and the joints staggered at about a 90° rotation from each preceding joint.

If coil packing is used, cut one ring to accurate size with either a butt or mitered joint. An accurately cut butt joint is superior to a poor fitting mitered joint. Fit the ring over the shaft to assure proper length. Then remove and cut all other rings to the first sample. When the rings are placed around the shaft a tight joint should be formed. Place the first ring in the bottom of the stuffing box. Then install each succeeding ring, staggering the joints as described above, making sure each ring is firmly seated.

If your pump is supplied with seal cages (optional) make sure the seal cages are properly located in the stuffing boxes under the sealing water inlets. The function of the seal cage is to establish a liquid seal around the shaft, prevent leakage of air through the stuffing box and lubricate the packing. If it is not properly located it serves no purpose.

MECHANICAL SEALS

General instructions for operation of the various mechanical sealing arrangements are included below. It is not feasible to include detailed instructions for all mechanical seals in this booklet because of the almost unlimited number of possible combinations and arrangements. Instead, seal manufacturer's instructions will be included as a separate supplement to this book, where required.

- a. Mechanical seals are precision products and should be treated with care. Use special care when handling seals. Clean oil and clean parts are essential to prevent scratching the finely lapped sealing faces. Even light scratches on these faces could result in leaky seals.
- b. Normally, mechanical seals require no adjustment or maintenance except routine replacement of worn or broken parts.
- c. A mechanical seal which has been used should not be put back into service until the sealing faces have been replaced or relapped. (Relapping is generally economical only in seals two inches in size and above.)

Four important rules which should always be followed for optimum seal life are:

1. Keep the seal faces as clean as possible.
2. Keep the seal as cool as possible.
3. Assure that the seal always has proper lubrication.
4. If seal is lubricated with filtered fluid, clean filter frequently.

TROUBLESHOOTING

Between regular maintenance inspections, be alert for signs of motor or pump trouble. Common symptoms are listed below. Correct any trouble immediately and **AVOID COSTLY REPAIR AND SHUTDOWN.**

Problem	Item	Probable Cause	Remedy
No Liquid Delivered	1	Lack of prime.	Fill pump and suction pipe completely with liquid.
	2	Loss of prime.	Check for leaks in suction pipe joints and fittings; vent casing to remove accumulated air. Check mechanical seal or packing.
	3	Suction lift too high (a negative suction gauge reading).	If there is no obstruction at inlet and suction valves are open, check for pipe friction losses. However, static lift may be too great. Measure with mercury column or vacuum gauge while pump operates. If static lift is too high, liquid to be pumped must be raised or pump lowered.
	4	System static head too high.	Check with factory to see if a larger impeller can be used; otherwise, cut pipe losses or increase speed — or both, as needed. But be careful not to seriously overload driver.
	5	Speed too low.	Check whether motor is directly across-the-line and receiving full voltage. Frequency may be too low. Motor may have an open phase.
	6	Wrong direction of rotation.	Check motor rotation with directional arrow on pump casing. If rotation is correct with arrow, check the relationship of the impeller with casing. (This will require removing casing upper half.)
	7	No rotation.	Check power, coupling, line shaft and shaft keys.
	8	Impeller loose on shaft.	Check key, locknut and set screws.
	9	Impeller completely plugged.	Dismantle pump and clean impeller.
	10	System head or required discharge head too high.	Check pipe friction losses. Large piping may correct condition. Check that valves are wide open.
Not Enough Liquid Delivered	11	Air leaks in suction piping.	If liquid pumped is water or other non-explosive and explosive gas or dust is not present, test flanges for leakage with flame or match. For such liquids as gasoline, suction line can be tested by shutting off or plugging inlet and putting line under pressure. A gauge will indicate a leak with a drop of pressure.
	12	Air leaks in stuffing box.	Replace packing and sleeves if appropriate or increase seal lubricant pressure to above atmosphere.
	13	Speed too low.	See item 5.
	14	Discharge head too high.	See item 10.
	15	Suction lift too high.	See item 3.
	16	Impeller partially plugged	See item 9.
	17	Cavitation; insufficient NPSHA (Net Positive Suction Head Available).	a. Increase positive suction head on pump by lowering pump or increasing suction pipe and fittings size. b. Sub-cool suction piping at inlet to lower entering liquid temperature. c. Pressurize suction vessel.

Problem	Item	Probable cause	Remedy
Not Enough Liquid Delivered <i>(cont.)</i>	18	Defective Impeller and/or wear rings.	Inspect impeller and wear rings. Replace if damaged or vane sections are badly eroded or if wear ring clearance is 3 times normal.
	19	Foot valve too small or partially obstructed.	Area through ports of valve should be at least as large as area of suction pipe (preferably 1.5 times). If strainer is used, net clear area should be 3 to 4 times area of suction pipe.
	20	Suction inlet not immersed deep enough.	If inlet cannot be lowered or if eddies through which air is sucked persists when it is lowered, chain a board to suction pipe. It will be drawn into eddies, smothering the vortex.
	21	Wrong direction of rotation.	Symptoms are an overloaded driver and about one third rated capacity from pump. Compare rotation of motor with directional arrow on pump casing. If rotation is correct with arrow, impeller may have to be turned 180°. (See CHANGING ROTATION)
	22	System head too high.	See item 4.
	23	Defective mechanical seal.	Repair or replace seal.
Not Enough Pressure	24	Speed too low.	See item 5.
	25	Air leaks in suction piping or stuffing box.	See item 11.
	26	Mechanical defects.	See item 18.
	27	Vortex at suction inlet.	See item 20.
	28	Obstruction in liquid passages.	Check to see if suction and discharge valves are fully open. Dismantle pump and inspect passages and casing. Remove obstruction.
	29	Air or gases in liquid.	May be possible to over rate pump to a point where it will provide adequate pressure despite condition. Better provide gas separation chamber on suction line near pump and periodically exhaust accumulated gas. See item 17.
Pump Operates For a Short Time, Then Stops	30	Insufficient NPSHA.	See item 17.
	31	System head too high.	See items 4 & 10.
Pump Takes Too Much Power	32	Head lower than rating; thereby pumping too much liquid.	Machine impeller's O.D. to size advised by factory, or reduce speed.
	33	Cavitation.	See item 17.
	34	Mechanical defects.	See items 18, 19, 21, and 23.
	35	Suction inlet not immersed.	See item 20.
	36	Liquid heavier (in either viscosity or specific gravity) than allowed for.	Use larger driver. Consult factory for recommended size. Test liquid for viscosity and specific gravity.
	37	Wrong direction of rotation.	See item 6.
	38	Stuffing box glands too tight.	Release gland pressure. Tighten reasonably. If sealing liquid does not flow while pump operates, replace packing.

Pump Takes Too Much Power	39	Casing distorted by excessive strains from suction or discharge piping.	Check alignment. Examine pump for rubbing between impeller and casing. Replace damaged parts. Re-pipe pump.
	40	Shaft bent due to damage — through shipment, operation, or overhaul.	Check deflection of rotor by turning on bearing journals. Total indicator run-out should not exceed .002" on shaft and .004" on impeller wearing surface.
	41	Mechanical failure of critical pump parts.	Check wear rings and impeller for damage. Any irregularity in these parts will cause a drag on shaft.
	42	Misalignment.	Realign pump and driver.
	43	Speed may be too high.	Check voltage on motor. Check speed versus pump nameplate rating.
	44	Electrical defects.	The voltage and frequency of the electrical current may be lower than that for which motor was built, or there may be defects in motor. The motor may not be ventilated properly do to a poor location.
	45	Mechanical defects in turbine, engine or other type of drive exclusive of motor.	If trouble cannot be located consult factory.

DISASSEMBLY & REASSEMBLY

PROCEDURES. 37
CHANGING ROTATION. 38
DISMANTLING (PUMP WITH PACKING) 39
ASSEMBLY (PUMP WITH PACKING). 40
 Pumps With Grease Lubrication. 41
 Pumps With Oil Lubrication. 41
DISMANTLING (PUMP WITH MECHANICAL SEALS). 43
ASSEMBLY WITH MECHANICAL SEALS 44
 Pumps with Grease Lubrication 45
 Pumps with Oil Lubrication 45
ADJUSTABLE WEAR RINGS 47
 Adjustment. 47
 Disassembly and Reassembly 47
OIL LUBRICATED BEARINGS 48
VERTICAL UNITS 49
 Upper Casing Half Removal. 49
 Rotating Element Removal 50
 Reassembly of Rotating Element 50
 Replacing Upper Casing Half 51
 Complete Pump Removal 51
LIMITED END FLOAT COUPLINGS. 52

PROCEDURES

The procedures outlined in this section cover the dismantling and reassembly of two different types of 9100 Series pump construction.

- A. 9100 Series pump with packing.
- B. 9100 Series pump with mechanical seals.

Each procedure provides the step-by-step instructions for dismantling and then reassembling the pump, depending upon the type of shaft seal used.

When working on the pump, use accepted mechanical practices to avoid unnecessary damage to parts. Check clearances and conditions of parts when pump is

dismantled and replace if necessary. Steps should usually be taken to restore impeller and casing ring clearance when it exceeds three times the original clearance.

If your pump has adjustable wear rings, see Adjustable Wear Rings in the Disassembly & Reassembly Section.

	CAUTION
<i>For pumps in a vertical configuration (half pedestal or full pedestal), please follow the instructions for the disassembly and reassembly in the Vertical Units (Half and Full Pedestal) Section.</i>	

CHANGING ROTATION

9100 Series centrifugal pumps can be operated clockwise or counterclockwise when viewed from the coupling end of the pump (Fig. 15). If you wish to reverse the suction and discharge nozzles; i.e., change rotation, this can be accomplished with the same pump as follows:

1. Remove the impeller from the shaft, turn it 180° and replace it on the shaft. (Follow the disassembly procedures given in this manual.)
2. With the rotating element out of the casing, remove the casing from the baseplate and turn 180°. (Factory baseplates are drilled for both rotations.)
3. Set the rotating element back in the casing and reassemble the pump.

NOTE: *The impeller and casing are in the same relationship to each other as they were originally. The shaft and motor are also in the same relationship to each other as they were originally.*

4. Reassemble the pump and realign the coupling as called for in the alignment instructions.
5. The rotation of the motor must be changed by switching motor leads.

NOTE: *Unless the motor rotation is reversed the impeller will run backward.*



CAUTION

Check motor fan to make sure it is bi-directional. If not, motor fan will have to be turned around or replaced. Failure to do this could cause motor to run hot.

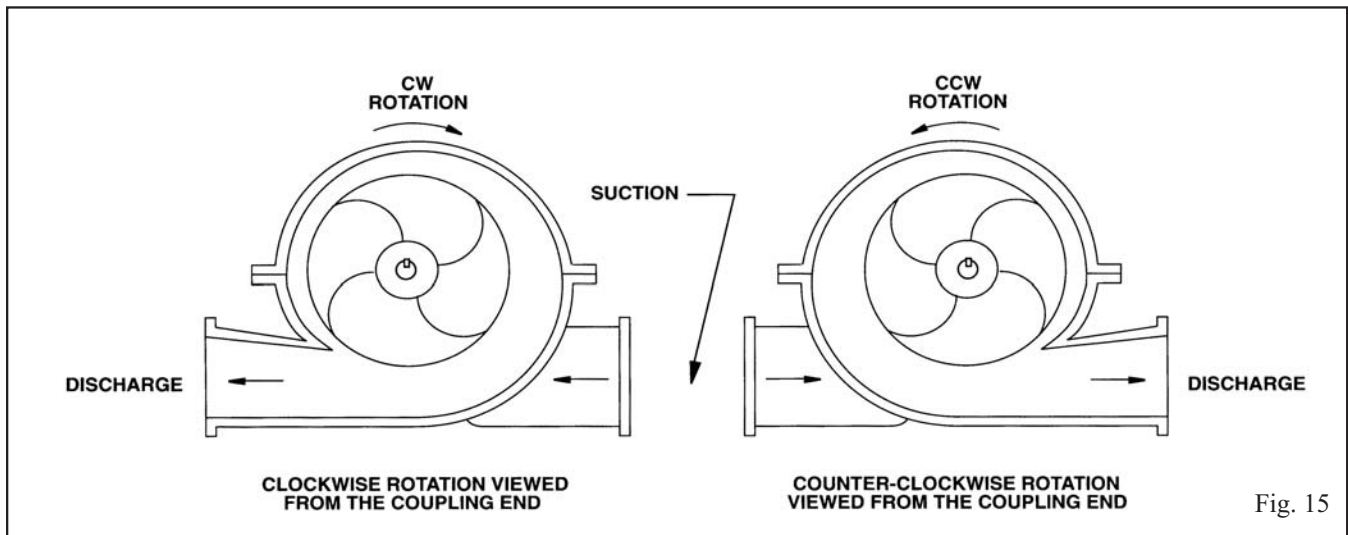

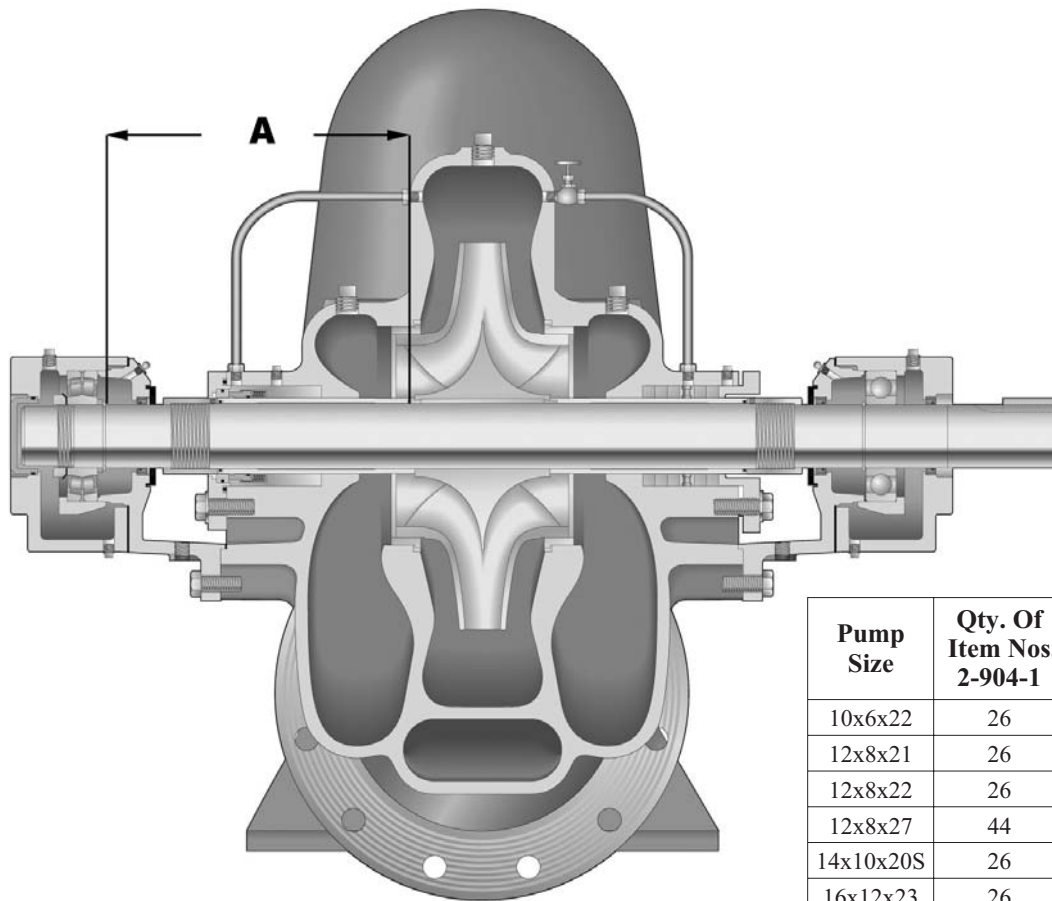

Pump Size	Qty. Of Item Nos. 2-904-1	Dimension A
10x6x22	26	13.50
12x8x21	26	
12x8x22	26	
12x8x27	44	15.81
14x10x20S	26	
16x12x23	26	
16x14x17	24	
18x14x23	32	
18x14x28	34	16.60
14x10x20L	26	

Fig. 16

DISMANTLING (PUMP WITH PACKING)



WARNING

Prior to working on the pump, the power source should be disconnected with lockout provisions so the power cannot be re-energized to the motor. Close isolating and discharge valves. Failure to follow these instructions could result in property damage, severe personal injury, or death. (See Cross Sectional View in the Appendices.)

1. Drain pump by opening vent plug (0-910-0) and removing drain plugs (0-910-0) on suction and discharge nozzle.
2. Remove coupling guard and separate the coupling to disconnect the pump from the driver.
3. Remove seal lines (0-952-0), if supplied.
4. Remove gland bolts (1-904-9), washers (1-909-9), and gland (1-014-2) from each stuffing box.
5. Remove all casing main joint cap screws (2-904-1) and dowels (2-916-9). Use slot in casing main joint and separate the casing halves with a pry bar. Lift upper half casing (2-001-0) by cast lugs.
6. Remove packing (1-924-0) and seal cage (3-013-2) from each stuffing box.
7. Remove cap screws (3-904-9) which hold bearing housings (3-025-2) to the casing and lift rotating element (See Fig. 17) out of lower half casing (2-001-0). Rotating element may now be moved to a suitable working location.

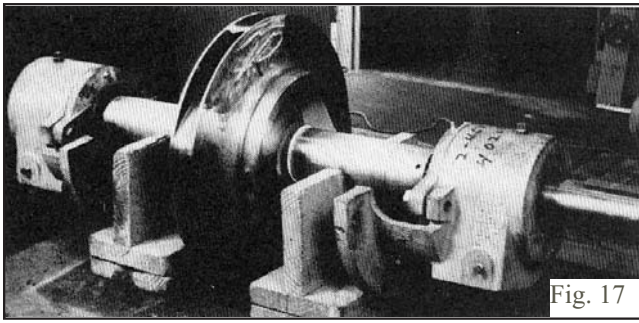

8. Pull coupling half and key (3-911-2) off shaft (3-007-0).

NOTE: A spare rotating element can be installed at this point.

9. Remove cap screws (3-904-9) from bearing covers (3-018-4 and 3-018-3).
10. Remove bearing housings (3-025-2), locknut (3-516-4), and lockwasher (3-517-4). Mount bearing puller and remove bearings (3-026-3 and 3-026-4). Remove thrust washer (3-078-9) and snap rings (3-915-9).

NOTE: Locknut, lockwasher, and thrust washer are not used on inboard bearing.

! **CAUTION**

Do not reuse ball bearings.

11. Remove bearing covers (3-018-4 and 3-018-3) and push bearing isolators out of bearing covers and coupling end bearing housing (3-177-3 and 3-177-9).
12. Remove casing rings (3-003-9) from impeller (4-002-0).
13. Remove set screw (3-902-9) from shaft nuts. Remove shaft nuts (3-015-9), O-rings (3-914-9), sleeves (3-009-9), sleeve gaskets (0-914-3), and impeller (4-002-0).

NOTE: Apply heat uniformly to the shaft sleeve to loosen the sealant between the shaft and sleeve. **DO NOT HEAT ABOVE 275° F.** To further assist in removing the sleeves, hold the shaft vertically and tap it on a block of wood. The impeller weight should force both the impeller and sleeve from the shaft.

14. See Adjustable Wear Rings Section if pump is equipped with adjustable rings.

NOTE: For impellers with replaceable rings — remove the rings (4-004-0) by cutting the rings with a cold chisel. (See Fig. 18)

ASSEMBLY (PUMP WITH PACKING)

All bearings, O-rings, seals, gaskets, impeller rings, and casing wear rings should be replaced with new parts during assembly. All reusable parts should be cleaned of all foreign matter before reassembling. The main casing joint gasket should be made using the lower half as a template. Lay the gasket material on the casing joint and mark it by pressing it against the edges of the casing. Trim the gasket so that it is flush with the inside edges of the casing.

NOTE: Precut casing gaskets (2-123-6 and 2-123-5) can be ordered to minimize the amount of trimming.

1. Place impeller key (3-911-1) in shaft (3-007-0).
2. Check the impeller (4-002-0) and casing (2-001-0) to determine the correct impeller rotation (See Fig. 15) and locate the impeller on the shaft per dimension “A”. (See Fig. 16)

NOTE: For impellers with replaceable rings, heat each new ring (4-004-0) and slide it onto the impeller. Hold rings against the impeller shoulder until they cool. (See Fig. 19)

3. Place both shaft sleeve keys (3-911-3) on shaft (3-007-0).
4. Slide sleeve gaskets (0-914-3) onto shaft and against hubs of impeller.
5. Slide sleeves (3-009-9) onto shaft.
6. Place the sleeve O-ring (3-914-9) onto the shaft, into the sleeve counterbore. Verify that Dimension “A” (Fig. 16) is maintained, then using a pin spanner wrench and hammer, securely tighten the shaft sleeve nuts (3-015-9). Then, drill a shallow recess in the shaft through the set screw hole in each of the shaft sleeve nuts. Lock each shaft sleeve nut in position with cup point set screws (3-902-9). (See Fig. 19) A low strength sealant, such as Loctite 271, can be used to retain set screws.

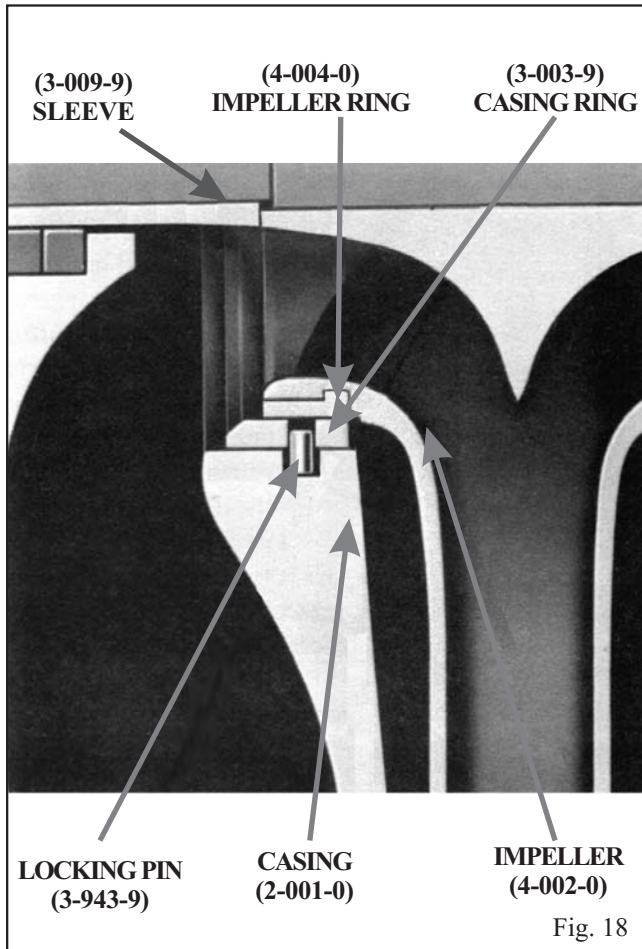

Fig. 18

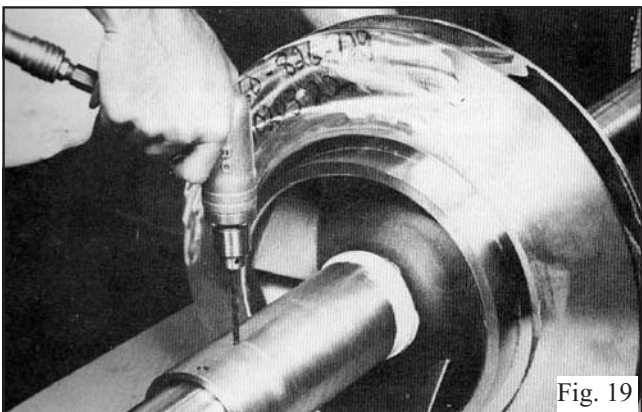

Fig. 19

7. Assemble casing rings (3-003-9). (See Adjustable Wear Ring Section, if required.)
8. Start heating bearings (3-026-3 and 3-026-4) so that they will be ready when called for in step 11. Use dry heat from induction heat lamps or electric furnace, or a 10-15% soluble oil and water solution.

! **CAUTION**

Do not exceed 275° F.

! **CAUTION**

These are precision, high quality bearings. Exercise care at all times to keep them clean and free of foreign matter.

9. Press inboard bearing isolators (3-177-9) in each bearing cover. Install gaskets (3-409-9) on each bearing cover.
10. Slide bearing covers (3-018-4 and 3-018-3) on the shaft. Install snap rings (3-915-9). Install thrust washer (3-078-9) on the outboard end.

NOTE: For ease of assembly and protection of rubber parts while sliding rubber parts onto shaft, cover O-ring groove, keyways, and threads with electrical tape.

NOTE: Inboard bearing cover (3-018-3) is approximately 1/4 inch less in width than the outboard bearing cover (3-018-4). This is the only dimensional difference.

11. Press heated bearing (3-026-3 and 3-026-4) on shaft against snap ring or thrust washer. Install locknut (3-516-4) and lockwasher (3-517-4) on outboard end. Make certain locknut is secured and then bend over tab on lockwasher.

PUMPS WITH GREASE LUBRICATION

12. Cool bearings at room temperature and coat with 2 or 3 ounces of a recommended grease.

PUMPS WITH OIL LUBRICATION

NOTE: Refer to Oil Lubricated Bearings Section for installation of oil lubricated parts.

13. Press outboard bearing isolator (3-177-3) in coupling end bearing housing.
14. Slide bearing housings (3-025-2) onto shaft (3-007-0) over bearings (3-026-3 and 3-026-4).
15. Assemble bearing cover to bearing housing with two cap screws (3-904-9).
16. Replace pump coupling half and key (3-911-2).
17. Assemble rotating element in lower half casing (2-001-0). Correctly locate casing ring pins (3-943-9) in casing main joint slot.

NOTE: *Sliding inboard bearing housing toward coupling prior to assembling rotating element in casing will ease assembly.*

18. Bolt outboard bearing housing in place. Be sure that both housings are seated properly in lower half casing.
19. Bolt inboard bearing housing in place.
20. Clean the gasket surfaces of the casing. Apply Scotch 3M-77 spray adhesive or equivalent to the lower half of the casing.
21. Within one minute of spraying, set the gaskets (2-123-6 and 2-123-5) in place on the lower half casing, align the holes in the gaskets with the holes in the casing and press the gaskets firmly against the lower half casing face in the area coated by the adhesive.
22. Lower upper half casing (2-001-0) into place (See Fig. 20) and locate using the taper dowels (2-916-9) and install casing main joint bolts (2-904-1). The casing joint bolts should be tightened to the following torques: 300 ft-lb minimum for .75"-10 Ferry Cap Countr-bor screws (Grade 8), 400 ft-lb minimum for 1.0"-8 Ferry Cap Countr-bor screws (Grade 8). Bolt torquing pattern is shown in Fig. 39. The number of casing bolts varies with the size of the pump. (See Fig. 16) Before tightening bolts, be sure taper dowels are seated properly in reamed holes.

NOTE: *Torquing bolts to proper values in proper sequence is essential in obtaining proper gasket compression so no leakage can occur at main joint.*

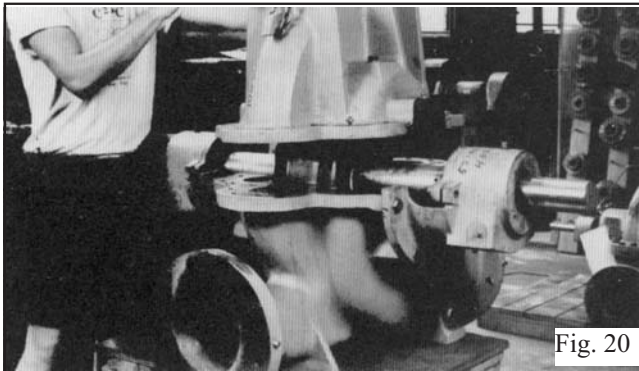

CAUTION

Double check rotation of pump before installing the upper half casing. (Refer to Fig. 15)

23. Rotate shaft by hand to assure that it turns smoothly and is free from rubbing and binding.

24. Cut full rings of 5/8 inch square packing so that ends butt, leaving no gap between packing and casing. Install three rings of packing (1-924-0) and tap fully to bottom of both stuffing boxes (See Fig. 21). Stagger joints of each ring of packing at least 90°. Install seal cage (3-013-2) (if this optional part was supplied) and be sure that it will line up with seal water inlet when packing is compressed. Install remaining two rings of packing (three rings if no seal cage present) with joints staggered. Assemble glands (1-014-2) square with stuffing box and pull up tight. Then loosen gland bolts (1-904-9) to permit packing to expand, and retighten finger tight. Final adjustment of gland bolts must be done when pump is running. Allow 30 minutes between adjustments (See Fig. 22).
25. If supplied, assemble seal water lines (0-952-0) to stuffing box and casing. Seal water lines should be piped to the tapped holes nearest impeller (See Fig. 16).
26. Check coupling alignment and redowel if necessary.

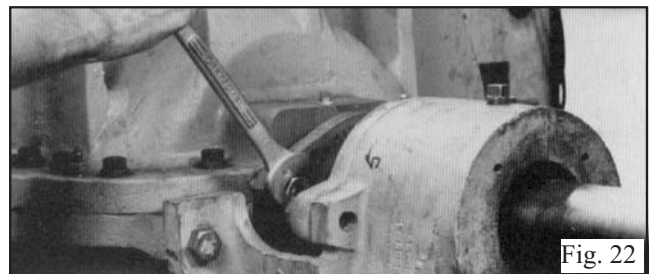

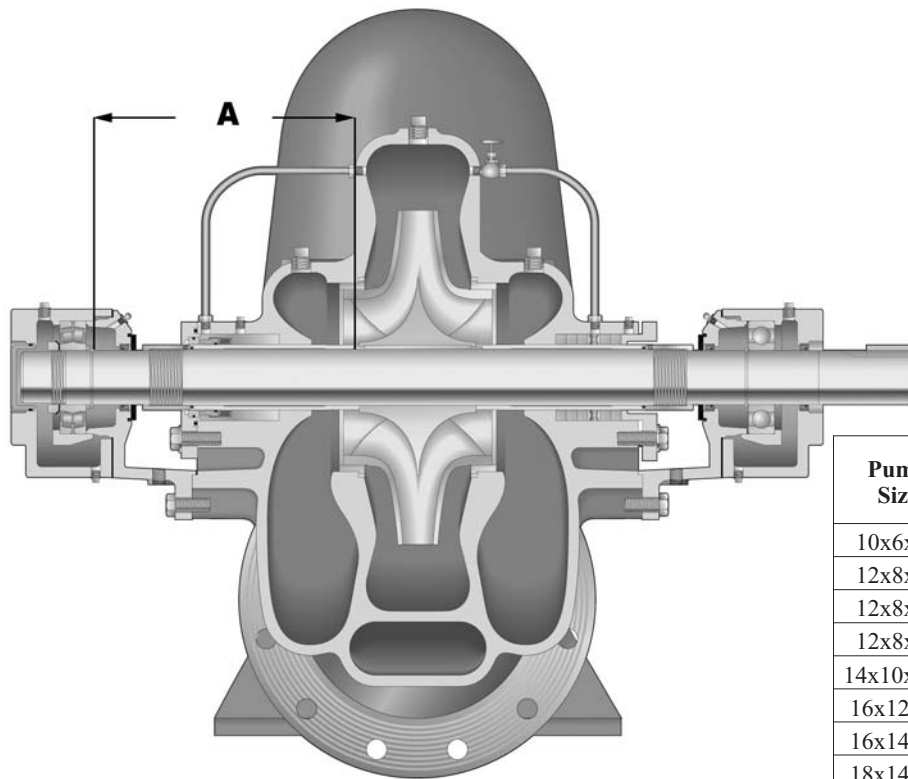

Pump Size	Qty. of Item nos. 2-904-1	Dimension A
10x6x22	26	13.50
12x8x21	26	
12x8x22	26	
12x8x27	44	15.81
14x10x20S	26	
16x12x23	26	
16x14x17	24	
18x14x23	32	
18x14x28	34	16.60
14x10 x20L	26	

Fig. 23

DISMANTLING (PUMP WITH MECHANICAL SEALS)



WARNING

Prior to working on the pump, the power source should be disconnected with lockout provisions so the power cannot be re-energized to the motor. Close isolating and discharge valves. Failure to follow these instructions could result in property damage, severe personal injury, or death (See Cross Sectional View in the Appendices).

1. Drain pump by opening vent plug (0-910-0) and removing drain plugs (0-910-0) on suction and discharge nozzle.
2. Remove coupling guard and separate the coupling to disconnect the pump from the driver.
3. Remove seal lines (0-952-0), if supplied.
4. Remove gland bolts (1-904-9) and slide gland (3-014-2) away from casing.
5. Remove all casing main joint cap screws (2-904-1) and dowels (2-916-9). Use slot in casing main joint and separate the casing halves with a pry bar. Lift upper half casing (2-001-0) by cast lugs.

6. Remove cap screws (3-904-9) which hold bearing housings (3-025-2) to the casing and lift rotating element out of lower half casing (2-001-0). Rotating element may now be moved to a suitable working location.
7. Pull coupling half and key (3-911-2) off shaft (3-007-0).

NOTE: A spare rotating element can be installed at this point.

8. Remove cap screws from bearing covers (3-018-4 and 3-018-3).
9. Remove bearing housings (3-025-2), locknut (3-516-4), and lockwasher (3-517-4). Mount bearing puller and remove bearings (3-026-3 and 3-026-4). Remove thrust washer (3-078-9) and snap rings (3-915-9).

NOTE: Locknut, lockwasher, and thrust washer are not used on inboard bearing.



CAUTION

Do not reuse ball bearings.

10. Remove bearing covers (3-018-4 and 3-018-3) and push bearing isolators (3-177-3 and 3-177-9) out of bearing covers and coupling end bearing housing.
11. Remove glands (3-014-2). Loosen set screws and remove mechanical seal head assembly (3-400-0). Press mechanical seal seats (3-400-0) from glands.
12. Remove casing rings (3-003-9) from impeller (4-002-0).
13. Remove set screw (3-902-9) from shaft nuts. Remove shaft nuts (3-015-9), O-rings (3-914-9), sleeves (3-009-9), sleeve gaskets (0-914-3), and impeller (4-002-0).

NOTE: Apply heat uniformly to the shaft sleeve to loosen the sealant between the shaft and sleeve. **DO NOT HEAT ABOVE 275° F.** To further assist in removing the sleeves, hold the shaft vertically and tap it on a block of wood. The impeller weight should force both the impeller and sleeve from the shaft.

14. Refer to Adjustable Wear Ring Section if pump is equipped with adjustable rings.

NOTE: For impellers with replaceable rings - remove the rings (4-004-0) by cutting the rings with a cold chisel.

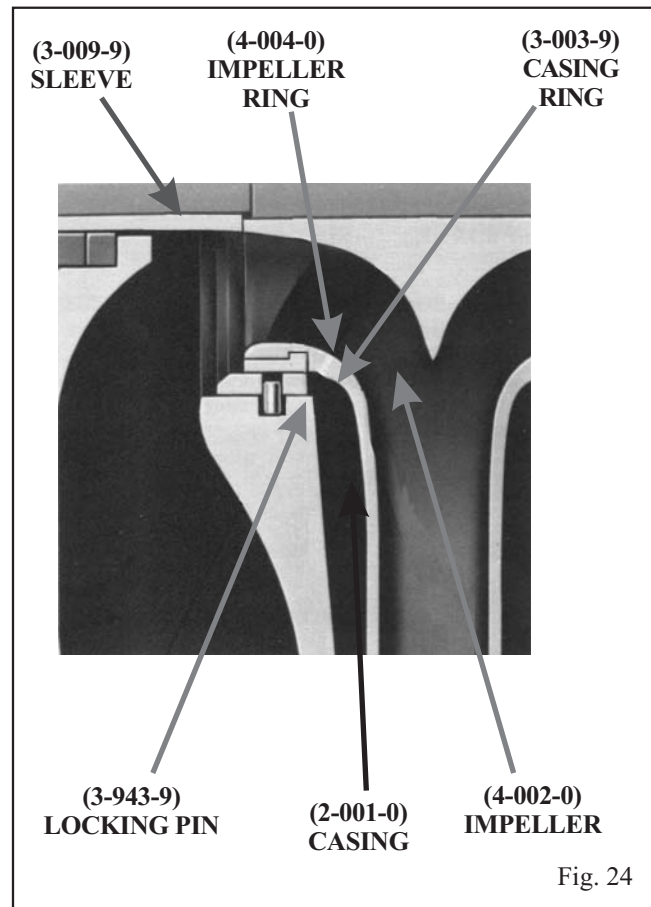

Fig. 24

ASSEMBLY (PUMP WITH MECHANICAL SEALS)

All bearings, O-rings, seals, gaskets, impeller rings, and casing wear rings should be replaced with new parts during assembly. All reusable parts should be cleaned of all foreign matter before reassembling. The main casing joint gasket should be made using the lower half as a template. Lay the gasket material on the casing joint and mark it by pressing it against the edges of the casing. Trim the gasket so that it is flush with the inside edges of the casing.

NOTE: Precut casing gaskets (2-123-6 and 2-123-5) can be ordered to minimize the amount of trimming.

1. Place impeller key (3-911-1) in shaft (3-007-0).
2. Check the impeller (4-002-0) and casing (2-001-0) to determine the correct impeller rotation (See Fig. 15) and locate the impeller on the shaft per dimension "A". (See Fig. 23)

NOTE: For impellers with replaceable rings, heat each new ring (4-004-0) and slide it onto the impeller. Hold rings against the impeller shoulder until they cool. (See Fig. 24)

3. Place both shaft sleeve keys (3-911-3) on shaft (3-007-0).
4. Slide sleeve gaskets (0-914-3) onto shaft and against hubs of impeller.
5. Slide sleeves (3-009-9) onto shaft.
6. Place the sleeve O-ring (3-914-9) onto the shaft, into the sleeve counterbore. Verify that Dimension "A" (Fig. 23) is maintained, then using a pin spanner wrench and hammer, securely tighten the shaft sleeve nuts (3-015-9). Then, drill a shallow recess in the shaft through the set screw hole in each of the shaft sleeve nuts. Lock each shaft sleeve nut in position with cup point set screws (3-902-9). (See Fig. 25) A low strength sealant, such as Loctite 271, can be used to retain set screws.

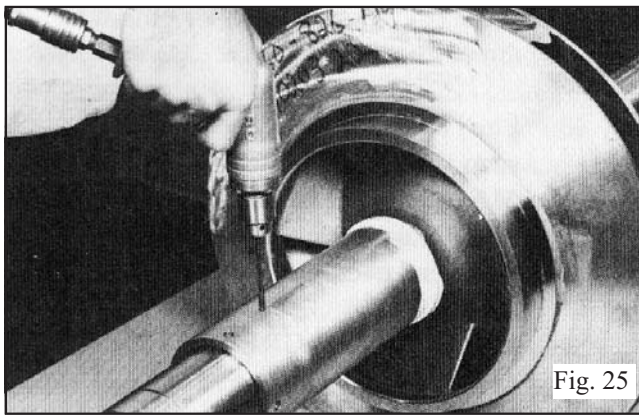

Fig. 25

7. Assemble casing rings (3-003-9). (See Adjustable Wear Ring Section, if required.)
8. Install stationary seats (3-400-0) into the glands (3-014-2) with lapped surface facing outward.

NOTE: Do not scratch or damage seal faces during assembly. Stationary seat must bottom squarely in gland.

9. Apply fine coat of silicon grease or equivalent to shaft sleeve, and slide seal head assembly (3-400-0) over sleeve. (See Fig. 26) If seal is a John Crane Type 8, set seal to approximate dimension shown in Fig. 28 and tighten set screws. Next, install O-rings (3-914-2) onto glands (3-014-2) and install glands on the shaft.



CAUTION

Do not use petroleum-based products for installing mechanical seal head as it may attack the rubber elastomers.

10. Start heating bearings (3-026-3 and 3-026-4) so that they will be ready when called for in step 13. Use dry heat from induction heat lamps or electric furnace, or a 10-15% soluble oil and water solution.



CAUTION

Do not exceed 275° F.



CAUTION

These are precision, high quality bearings. Exercise care at all times to keep them clean and free of foreign matter.

11. Press inboard bearing isolators (3-177-9) in each bearing cover. Install gaskets (3-409-9) on each bearing cover.

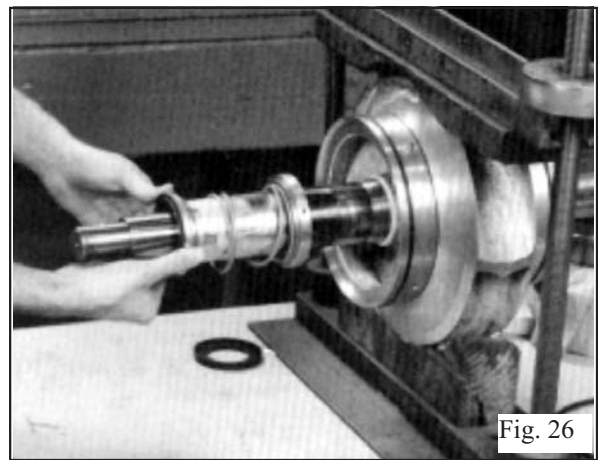

Fig. 26

12. Slide bearing covers (3-018-4 and 3-018-3) on the shaft. Install snap rings (3-915-9). Install thrust washer (3-078-9) on the outboard end.

NOTE: For ease of assembly and protection of rubber parts while sliding rubber parts onto shaft, cover O-ring groove, keyways, and threads with electrical tape.

NOTE: Inboard bearing cover (3-018-3) is approximately 1/4 inch less in width than the outboard bearing cover (3-018-4). This is the only dimensional difference.

13. Press heated bearing (3-026-3 and 3-026-4) on shaft against snap ring or thrust washer. Install locknut (3-516-4) and lockwasher (3-517-4) on outboard end. Make certain the locknut is secured and then bend over tab on lockwasher.

6

PUMPS WITH GREASE LUBRICATION

14. Cool bearings at room temperature and coat with 2 or 3 ounces of a recommended grease.

PUMPS WITH OIL LUBRICATION

NOTE: See Oil Lubricated Bearings Section for installation of oil lubricated parts.

15. Press outboard bearing isolator (3-177-3) in coupling end bearing housing.
16. Slide bearing housings (3-025-2) over bearings (3-026-3 and 3-026-4).
17. Assemble bearing cover to bearing housing with two cap screws (3-904-9).
18. Replace pump coupling half and key (3-911-2).

19. Assemble rotating element in lower half casing (2-001-0). Correctly locate casing ring pins (3-943-9) in casing main joint slot.

NOTE: *Sliding inboard bearing housing toward coupling prior to assembling rotating element in casing will ease assembly.*

20. Bolt outboard bearing housing in place. Be sure that both housings are seated in lower half casing.
21. Bolt inboard bearing housing in place. If seal is a John Crane Type 8, set seal to dimensional shown in Fig. 27 and tighten set screws.

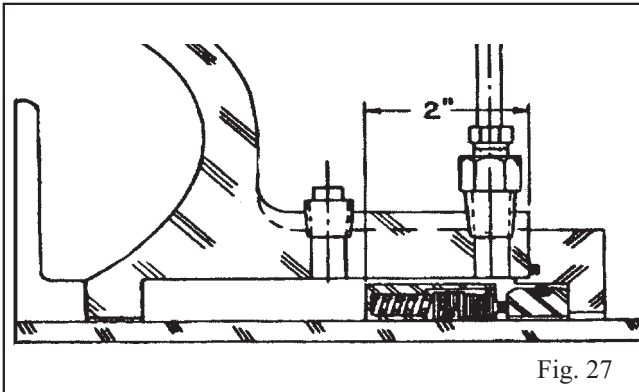

22. Clean the gasket surfaces of the casing. Apply Scotch 3M-77 spray adhesive or equivalent to the lower half of the casing.
23. Within one minute of spraying, set the gaskets (2-123-6 and 2-123-5) in place on the lower half casing, align the holes in the gaskets with the holes in the casing and press the gaskets firmly against the lower half casing face in the area coated by the adhesive.
24. Lower upper half casing (2-001-0) into place (See Fig. 28) and locate using the taper dowels (2-916-9) and install casing main joint bolts (2-904-1). The casing joint bolts should be tightened to the following torques: 300 ft-lb minimum for .75"-10 Ferry Cap Countr-bor screws (Grade 8), 400 ft-lb minimum for 1.0"-8 Ferry Cap Countr-bor screws (Grade 8). Bolt torquing pattern is shown in Fig. 39. The number of casing bolts varies with the size of the pump (See Fig. 23). Before tightening bolts, be sure taper dowels are seated properly in reamed holes.

NOTE: *Torquing bolts to proper values in proper sequence is essential in obtaining proper gasket compression so no leakage can occur at main joint.*

! **CAUTION**

Double check rotation of pump before installing the upper casing (Refer to Fig. 15).

25. Rotate shaft by hand to assure that it turns smoothly and is free from rubbing and binding.
26. Bolt glands (3-014-2) to casing with gland bolts (1-904-9).
27. Assemble seal water lines (0-952-0) to stuffing box and casing. Seal water lines should be piped to the tapped holes nearest bearings (See Fig. 23).
28. Check coupling alignment and redowel if necessary.

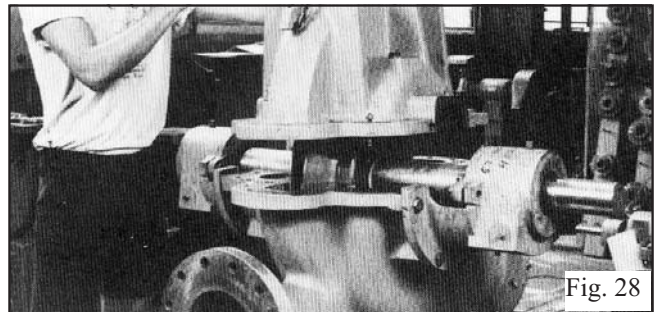

ADJUSTABLE WEAR RINGS

Adjustable rings are an assembly of two threaded rings (Fig. 29). The outer, stationary ring is held in the casing by a flange and an anti-rotation pin in the lower half main joint. The inner, adjustable ring can be moved axially, in either direction, by rotating it. The ring is held in position by a stainless steel locking pin. All rings have clockwise threads.

ADJUSTMENT

When the clearance between the impeller wear face and the adjustable wear ring becomes excessive; i.e., approximately .020" to .030", remove the upper half casing and pull the locking pin.

Rotate the inner rings clockwise to restore .005" - .008" clearance greater than shaft end float between the ring and the impeller. Drill a new hole in the inner ring for the locking pin. This is a blind hole — do not drill through. Replace the locking pin and upper half casing.

DISASSEMBLY AND REASSEMBLY

Adjustable rings are removed in the same manner as standard casing rings. They can be separated for cleaning. Adjustable rings are installed in the pump with stationary and the adjustable members assembled but not pinned. Turn the adjustable member counterclockwise to provide maximum impeller clearance and slide over shaft ends. With the rotating element in pump, the rings can be adjusted. Be sure that stationary member has its flange flush against casing lower half.

Move rotating element toward outboard end as far as bearings permit. Screw outboard end adjustable ring toward impeller to obtain .005" - .008" axial impeller clearance. Drill through stationary ring hole into adjustable ring and insert locking pin. Move rotating element toward coupling and set coupling end ring in the same manner.

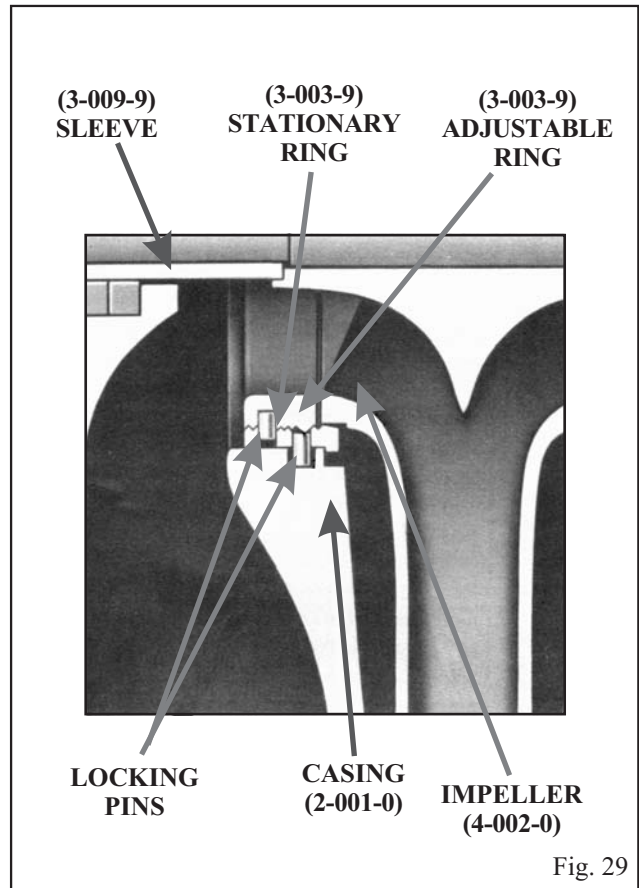

Fig. 29

OIL LUBRICATED BEARINGS

Figs. 30 and 31 show a grease lubricated bearing housing and an oil lubricated bearing housing, respectively. The main difference between the two is the grease fitting and the oil ring, respectively.

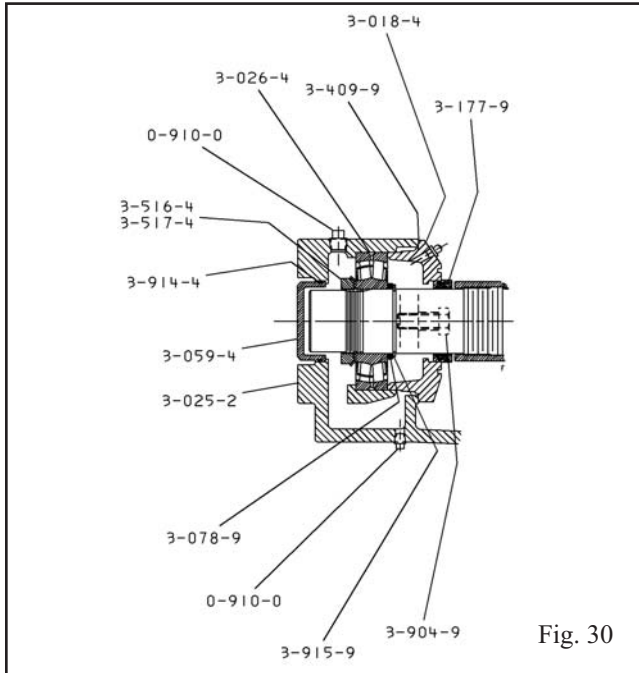

Fig. 30

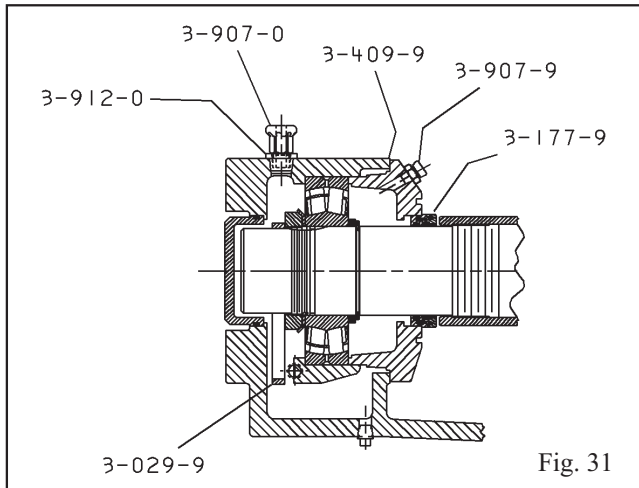

Fig. 31

To install the oil ring (4-907-0), place the oil ring in the bearing housing directly under the pipe plug hole. Run a wire through the pipe plug hole, around the oil ring and back through the pipe plug hole once again. Tie the wire to a metal washer (being a larger diameter than the hole) causing the oil ring to become tight against the inside top of the bearing housing. Then assemble the bearing housing over the bearing. Untie the wire and the oil ring will drop down onto the shaft. Check the position of the oil ring through the pipe plug hole at the top of the bearing housing. The oil ring must be resting on the shaft for correct operation. A screwdriver can be used to correct the oil ring position, if required.

The following steps describe how to change the oil for oil lubricating bearings. Fig. 32 shows a typical oiler assembly.

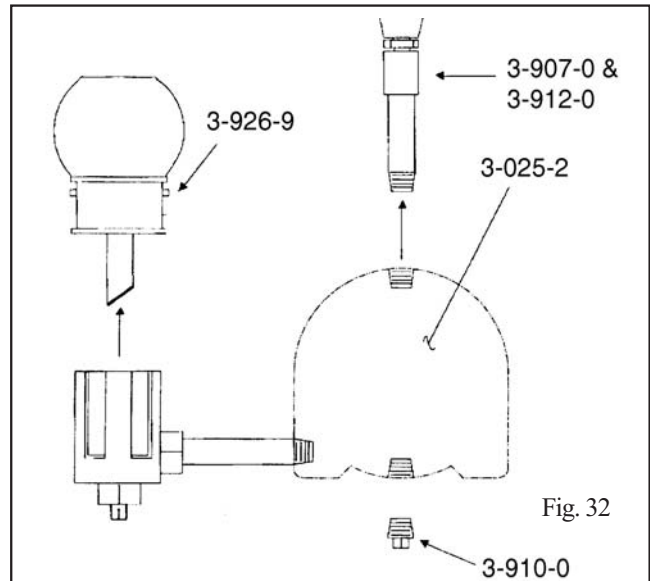

Fig. 32

1. Remove the vent assembly (3-907-0 and 3-912-0) from the top of the bearing housing (3-025-2).
2. Remove the pipe plug (0-910-0) from the bottom of the bearing housing (3-025-2).
3. Unscrew the reservoir (3-926-9) and remove.
4. Flush the oiler (3-926-9) and bearing housing (3-025-2) with a light grade of oil. Flush until all foreign particles have been removed.
5. Screw the pipe plug (0-910-0) and vent assembly (3-907-0 and 3-912-0) back into place.
6. Fill the reservoir (3-926-9) with a good grade of filtered mineral oil. Refer to oil lubrication instructions given previously in this manual for type of oil.

NOTE: You must fill through Trico reservoir.

7. Place thumb over reservoir spout, invert and place reservoir (251) on lower casting while removing thumb. Allow reservoir to empty, filling the bearing housing (134). Several fillings of the reservoir may be required before the actual level is reached. When the oil level is reached, no more oil will run out of the reservoir.
8. When reservoir stays full, screw reservoir back into lower casting.

A periodic filling of the reservoir is required. When the oil becomes dirty, repeat steps 1 through 8.

VERTICAL UNITS (HALF AND FULL PEDESTAL)

UPPER CASING HALF REMOVAL

NOTE: If only the upper half casing is to be removed for inspection of the rotating element, it will not be necessary to remove the line shafting or motor.

1. Do not loosen bolts (3-904-9) holding bearing housing (3-025-2) in casing until you are ready to remove rotating element from casing if necessary.



WARNING

Injury may result due to rotating element falling out of lower half casing if the above procedure is not followed. Failure to follow these instructions could result in property damage, severe personal injury, or death.

2. Remove the larger of the two pipe plugs from the top of the casing upper half and install an 18" to 24" solid bar threaded at one end into the exposed tapped hole. If a threaded bar is not available, it is permissible to use standard pipe.

NOTE: This bar will be used to stabilize upper half during disassembly of casing upper half. (See Fig. 33)

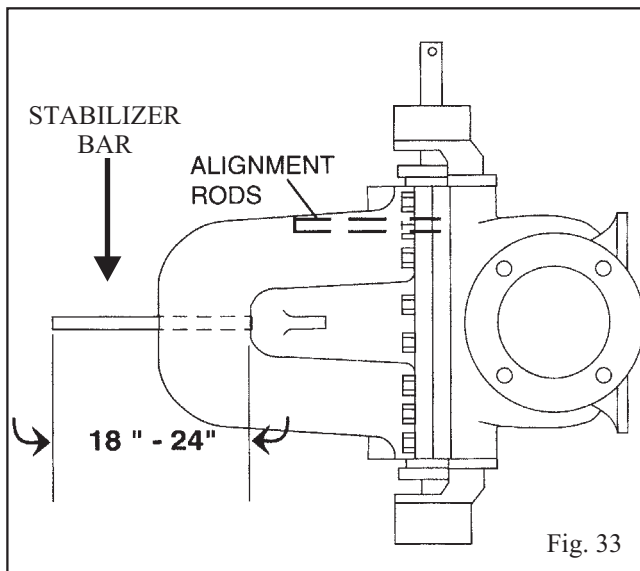

3. Disconnect the seal water lines at the stuff boxes and remove gland bolts.
4. Remove dowel pins and all parting line bolts except for two upper most and two lower most (See Fig. 34) Install alignment rods (see Fig. 33) through upper half and into tapped bottom half, one on suction side and one on discharge side above horizontal centerline of casing.

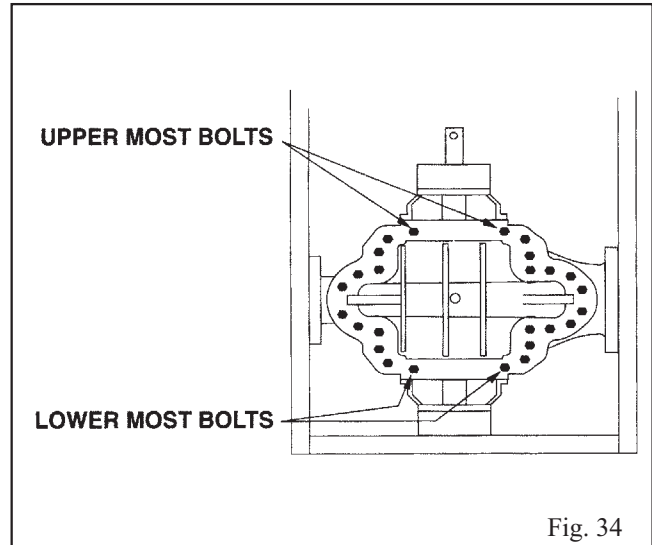

Fig. 34

NOTE: An alignment rod is a threaded rod that screws into bottom half of casing and is approximately 2" longer than one half the impeller diameter. This is to prevent the top half from falling down on impeller and also helps with alignment while installing upper half. If not supplied with pump, they can be made from threaded rod.

5. Sling around casing upper half ears using nylon sling, pulling slings taut so it is not possible for slings to slip off (See Fig. 35).

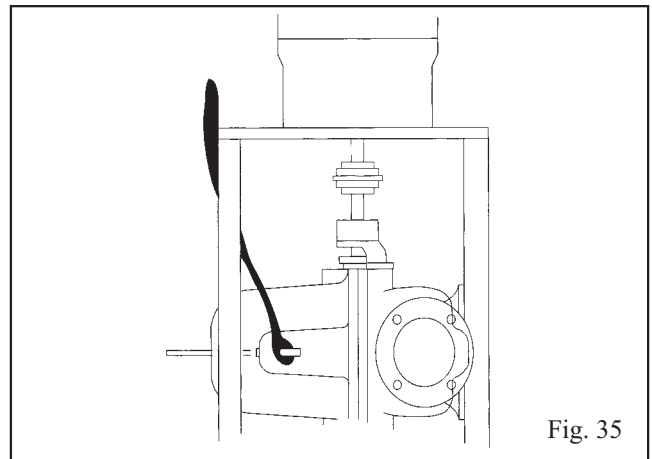

Fig. 35

6. Remove two lower most bolts and then one of the two upper most bolts.



CAUTION

Maintain downward pressure on the stabilizing rod during this step.

7. While maintaining a downward pressure on the stabilizer bar, unloosen the remaining upper most bolt.



WARNING

Do not remove completely at this point. Failure to follow these instructions could result in property damage, severe personal injury, or death.

8. Separate the upper and lower halves by use of a pry bar between the two halves or by the use of jacking screws if the top half is provided with tapped holes.
9. When halves separate, slide upper half away from lower half, maintain a downward pressure on the stabilizing rod end furthest from the pump and slowly remove completely the remaining upper most bolt. Allow the top half to slide on alignment rods.
10. Balancing the upper half with the stabilizing rod, lower the top half to the ground allowing the upper half to rotate so that its main joint flange sets on the ground (See Fig. 36).

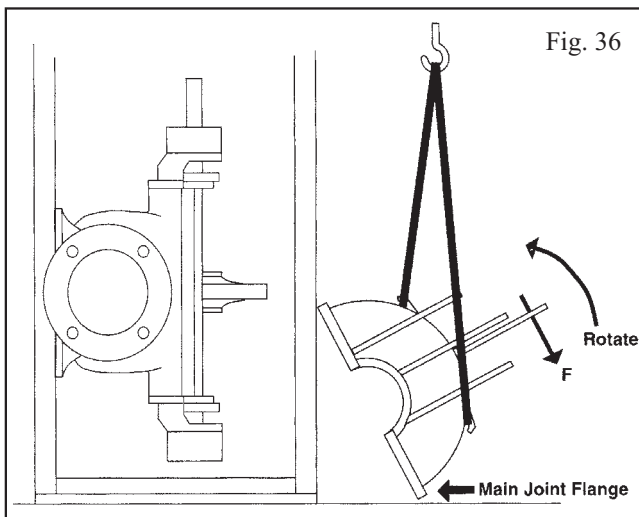

11. Rotating element is now ready for inspection or removal. If element is inspected and does not need to be removed, then refer to upper half reassembly procedures.

ROTATING ELEMENT REMOVAL

12. For these procedures it will be necessary to remove the line shafting or motor, then remove the pump half coupling.
13. Thread a long bolt, washer and nut through the hole at the end of the shaft. (See Fig. 37)
14. Sling around eye bolt, putting slight amount of tension on sling.
15. Remove the four bolts (3-904-9) from each bearing housing that are holding the bearing housing to the casing.

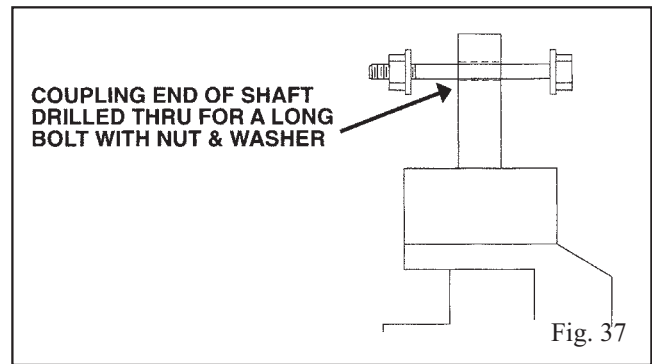

16. Lightly tapping on inboard and outboard bearing housings to spread them apart, slide rotating element away from lower half.
17. Lower rotating element to ground by sliding outboard bearing housing away from pedestal enabling element to be set on floor with shaft in a horizontal position. (See Fig. 38)

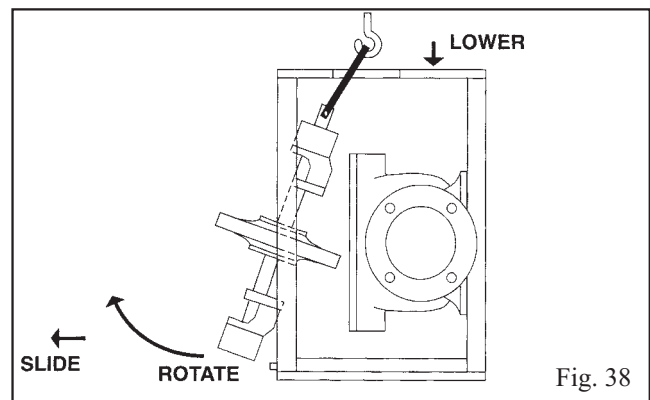

18. Rotating element can now be serviced following disassembly procedure given previously in this manual.

REASSEMBLY OF ROTATING ELEMENT

19. Inspect main joint gasket and replace if necessary. (Follow replacement instructions in disassembly procedures section.)
20. Sling around the bolt in end of pump shaft.
21. On full pedestals, the lifting sling must come through hole in top plate of pedestal (See Fig. 38).
22. When rotating element is off the ground and in the vertical position, align any anti-rotation pins in the casing rings and stuffing boxes for proper orientation in the slots in the casing lower half.
23. Assemble rotating element in lower half casing (2-001-0). Correctly locate casing ring pins (3-943-9) in casing main joint.

NOTE: Sliding inboard bearing housing toward coupling prior to assembling rotating element in casing will ease assembly.

24. Bolt the outboard bearing housing (3-025-2) to lower half casing (2-001-0) first.



CAUTION

Be sure that both bearing housing (3-025-2) are seated properly in lower half casing (2-001-0).

25. Bolt inboard bearing housing (3-025-2) to lower half casing (2-001-0).

NOTE: Check again to be sure bearing housings are seated properly in lower half casing.

REPLACING UPPER CASING HALF

26. Sling around lifting ears and with stabilizing rod installed, pick casing upper half off the ground and rotate top half so that main joint flange is vertical. (See Fig. 36 with rotation in opposite direction shown.)
27. Move upper half casing (2-001-0) towards lower half casing (2-001-0) using alignment rods located in lower half casing as guides.
28. Prior to complete engagement of upper half onto lower half, use dowel pins to guide the upper half into its final exact position.
29. Reinstall all main joints bolts, following tightening sequence illustrated in Fig. 39. The number of casing bolts varies with the size of the pump. (See Fig. 23) Torque bolts 300 ft-lb minimum for .75"-10 Ferry Cap Countr-bor screws (Grade 8) and 400 ft-lb minimum for 1.0"-8 Ferry Cap Countr-bor screws (Grade 8).

NOTE: Torquing bolts to proper values in proper sequence is essential in obtaining proper gasket compression so no leakage can occur at main joint.



CAUTION

If impeller was removed from shaft, double check rotation of pump before installing upper half casing (See Fig. 15).

30. Rotate shaft making sure it spins free. If the motor or line shafting has been removed it will now be possible to reinstall.

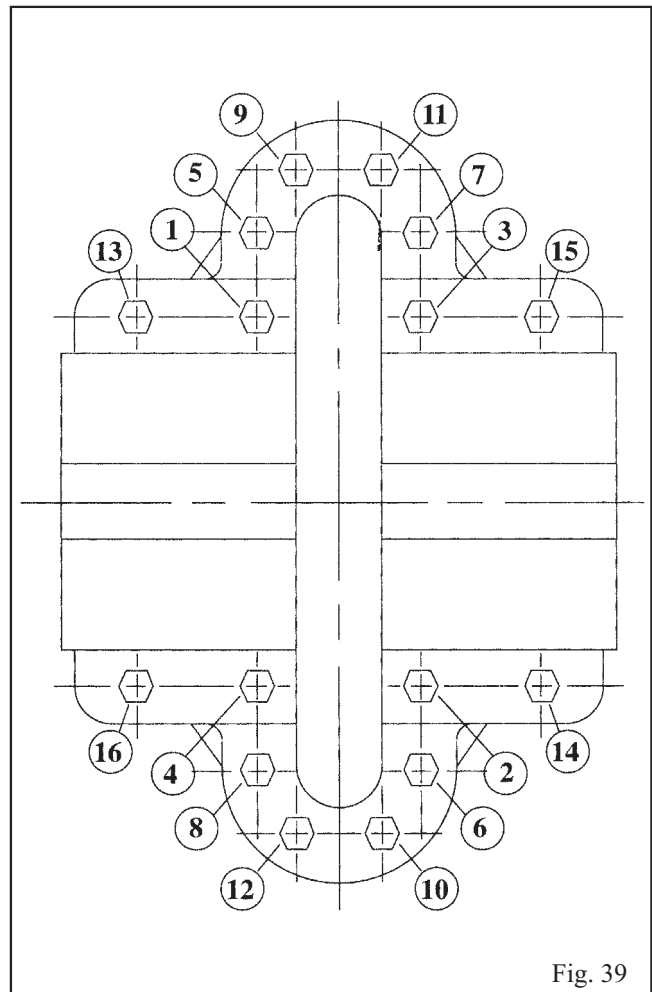

Fig. 39

COMPLETE PUMP REMOVAL

Should it be necessary to remove a complete pump, it will be necessary to remove the line shafting or motor, disconnect the pedestal from its anchor bolts, disconnect and remove if necessary sections of the suction and discharge piping, and turn the entire pedestal horizontal enabling complete pump removal from horizontal position.

LIMITED END FLOAT COUPLINGS

For units with drivers having sleeve bearings, the coupling halves are set to limit total shaft axial movement to less than one-half of the motor rotor assembly end float. This is accomplished by inserting a phenolic disc, or equivalent, of a specified thickness between the motor and pump shaft. (See Fig. 40)

Most 9100 Series pump installations use the all metal, gear type coupling. Where limited end float gear type couplings are used, the coupling hubs are slip-fit onto the pump and motor shafts. After installation of the coupling covers and hubs; with the motor set on its Magnetic Center, butt the pump and motor shafts with the phenolic disc inserted between them. (The pump thrust bearing limits end float toward the pump, and the coupling covers limit end float towards the motor.) The thrust bearing of the pump is large enough to carry any magnetic thrust developed by the motor when aligned properly.

Once the above instructions have been followed completely the Alignment Procedures found in the Installation section should then be followed.

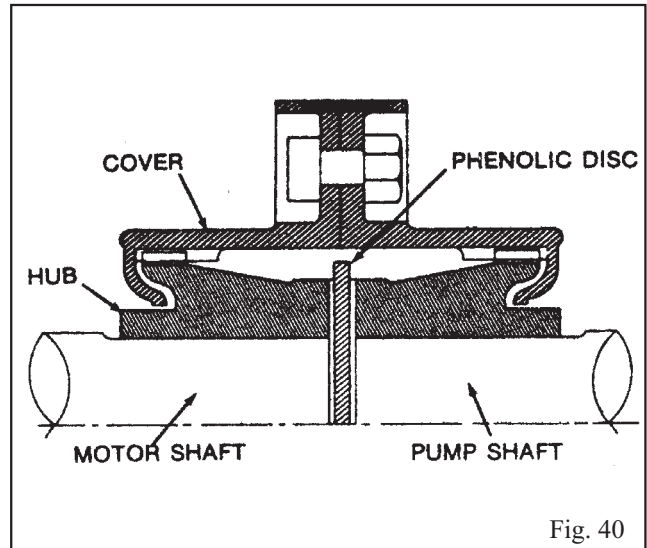

Fig. 40

APPENDIX I

INSTRUCTIONS FOR ORDERING PARTS

When ordering parts for 9100 Series pumps, be sure to furnish the following information to the A-C Pump stocking distributor in your area:

- Serial Number
- Pump Size & Type
- Pump Model Number
- Pump Frame Number
- Description of Part
- Catalog Code
- Quantity Required
- Definite Billing and Shipping Instructions
- Date Required

Refer to parts list on page 59 for a complete parts list and recommended spare parts.

Parts should be ordered as far in advance of their need as possible, since circumstances beyond the control of A-C Pump may reduce existing stocks. All parts are not carried in stock. Some are made for each order. If replacement parts required are to be made of different materials than originally specified, give exact requirements and the reason for changing. Special care in furnishing the above information with the original order for parts will facilitate shipment.

APPENDIX II

TOOLS

To disassemble and assemble 9100 Series pumps, use conventional tools.

APPENDIX III

ENGINEERING DATA

Pump Size	⑤ 10x6x22	⑤ 12x8x21	⑤ 12x8x22M	⑤ 12x8x22L	12x8x27
-----------	-----------	-----------	------------	------------	---------

CASING DATA

(All Dimensions in Inches)

② 125# FF Std. ASA Flanges	Max. Suction Pressure (PSIG)	75	75	75	75	Not Available
	Max. Working Pressure (PSIG)	300	300	300	300	
	Max. Hydrostatic Test Pressure (PSIG)	450	450	450	450	
	Casing Material	Cast Iron	Cast Iron	Cast Iron	Cast Iron	
① 250# FF ③ ASA Flanges	Max. Suction Pressure (PSIG)	200	200	200	200	200
	Max. Working Pressure (PSIG)	400	400	400	400	400
	Max. Hydrostatic Test Pressure (PSIG) ④	600	600	600	600	600
	Casing Material	Ductile Iron	Ductile Iron	Ductile Iron	Ductile Iron	Ductile Iron
	Casing Wall Thickness	.625	.625	.625	.625	.625

STUFFING BOX DATA

Bore	5.125	5.125	5.125	5.125	5.125	
Depth	4.812	4.812	4.812	4.812	4.812	
Seal Cage Width	.75	.75	.75	.75	.75	
Packing No. Rings/Size Sq.	6/.625	6/.625	6/.625	6/.625	6/.625	
Shaft Sleeve O.D.	3.875	3.875	3.875	3.875	3.875	
Mechanical Seal Size (Type 8-1)	3.875	3.875	3.875	3.875	3.875	
⑥ { Mechanical Seal Size (Type 8-1B)	{ Major Dia. Minor Dia.	4.125	4.125	4.125	4.125	4.125
		3.875	3.875	3.875	3.875	3.875

IMPELLER DESIGN DATA

Number of Vanes	6	6	5	6	6
Inlet Area (Sq. Inches)	59	35.7	61	80	82.4
Inlet Velocity per 100 GPM (Ft/Sec)	.54	.90	.53	.40	.37
Maximum Diameter	23.0	21.8	20.5	23.0	27.0
Minimum Diameter	12.0	12.5	12.5	12.0	20.0
Maximum Sphere	1.30	1.00	1.32	1.60	1.50
WR ² for Maximum Diameter (Lbs-Ft ²)	56	49	50	59	185
Wear Ring Clearance — Dia. BRZ Impellers	.016-.019	.016-.019	.016-.019	.016-.019	.016-.019
Wear Ring Clearance — Dia. CI and SS Impellers	.025-.028	.025-.028	.025-.028	.025-.028	.025-.028

SHAFT AND BEARING DATA

At Coupling	3.125	3.125	3.125	3.125	3.125
Thru Impeller and Sleeves	3.311	3.311	3.311	3.311	3.311
Shaft Span	Bearing to Bearing Centerline	35.800	35.800	35.800	40.500
Ball Bearing		Inboard	6316	6316	6316
	Outboard	21316	21316	21316	21316
Frame Group	S	S	S	S	M

① With 250# FF flanges refer to pump as H10x6x22.

② Flange dimensions are in accordance with ANSI A21.10, AWWA C110 and ANSI B16.1 Class125.

③ Flange dimensions are in accordance with ANSI B16.1 Class 250 except flanges are flat faced.

④ The hydrostatic test will be in accordance with the latest edition of the Hydraulic Institute Standards, test will be maintained for a minimum of 10 minutes.

⑤ 10x6x22, 12x8x21, and 12x8x22 M/L are standard with 125# FF suction and 250# FF discharge flanges.

⑥ Balanced mechanical seals have a major and a minor diameter as listed.

ENGINEERING DATA

Pump Size	14x10x20S	14x10x20L	16x12x23	16x14x17	18x14x23	18x14x28
-----------	-----------	-----------	----------	----------	----------	----------

CASING DATA

(All Dimensions in Inches)

②	125# FF Std.	Max. Suction Pressure (PSIG)	75	75	75	75	75	
	ASA Flanges	Max. Working Pressure (PSIG)	175	175	175	175	175	
		Max. Hydrostatic Test Pressure (PSIG)	262	262	262	262	262	
		Casing Material	Cast Iron	Cast Iron	Cast Iron	Cast Iron	Cast Iron	
①	250# FF	Max. Suction Pressure (PSIG)	200	200	200	200	200	
		③ ASA Flanges	Max. Working Pressure (PSIG)	300	300	300	300	300
			Max. Hydrostatic Test Pressure (PSIG) ④	450	450	450	450	450
			Casing Material	Ductile Iron	Ductile Iron	Ductile Iron	Ductile Iron	Ductile Iron
		Casing Wall Thickness	.625	.625	.625	.625	.625	

STUFFING BOX DATA

(All Dimensions in Inches)

Bore	5.125	5.125	5.125	5.125	5.875	5.875			
Depth	4.812	4.812	4.812	4.812	4.812	4.812			
Seal Cage Width	.75	.75	.75	.75	.75	.75			
Packing No. Rings/Size Sq.	6/.625	6/.625	6/.625	6/.625	6/.625	6/.625			
Shaft Sleeve O.D.	3.875	3.875	3.875	3.875	4.625	4.625			
Mechanical Seal Size (Type 8-1)	3.875	3.875	3.875	3.875	4.625	4.625			
⑥ {	Mechanical Seal	{	Major Dia.	4.125	4.125	4.125	4.125	4.750	4.750
	Size (Type 8-1B)		Minor Dia.	3.875	3.875	3.875	3.875	4.500	4.500

IMPELLER DESIGN DATA

(All Dimensions in Inches)

Number of Vanes	6	6	6	6	6	6
Inlet Area (Sq. Inches)	112	128	150	171	212	196
Inlet Velocity per 100 GPM (Ft/Sec)	.29	.25	.21	.19	.15	.16
Maximum Diameter	19.8	19.8	23.0	17.5	23.0	27.9
Minimum Diameter	9.4	14.0	13.0	12.5	14.0	14.0
Maximum Sphere	1.63	1.56	1.63	1.20	2.10	1.30
WR ² for Maximum Diameter (Lbs-Ft ²)	47	52	109	46	120	254
Wear Ring Clearance — Dia. BRZ Impellers	.016-.019	.016-.019	.016-.019	.016-.019	.016-.019	.016-.019
Wear Ring Clearance — Dia. CI and SS Impellers	.025-.028	.025-.028	.025-.028	.025-.028	.025-.028	.025-.028

SHAFT AND BEARING DATA

(All Dimensions in Inches)

At Coupling	3.125	3.125	3.125	3.125	3.125	3.125
Thru Impeller and Sleeves	3.311	3.311	3.311	3.311	4.061	4.061
Shaft Span	Bearing to Bearing Centerline					
	40.500	40.500	40.500	40.500	41.375	41.375
Ball Bearing	Inboard	6316	6316	6316	6316	6316
	Outboard	21316	21316	21316	21316	21316
Frame Group	M	M	M	M	L	L

- | | |
|--|--|
| <p>① With 250# FF flanges refer to pump as H10x6x22.</p> <p>② Flange dimensions are in accordance with ANSI A21.10, AWWA C110 and ANSI B16.1 Class125.</p> <p>③ Flange dimensions are in accordance with ANSI B16.1 Class 250 except flanges are flat faced.</p> | <p>④ The hydrostatic test will be in accordance with the latest edition of the Hydraulic Institute Standards, test will be maintained for a minimum of 10 minutes.</p> <p>⑤ 10x6x22, 12x8x21, and 12x8x22 M / L are standard with 125# FF suction and 250# FF discharge flanges.</p> <p>⑥ Balanced mechanical seals have a major and a minor diameter as listed.</p> |
|--|--|

APPENDIX IV

9100 SERIES CROSS-SECTIONAL

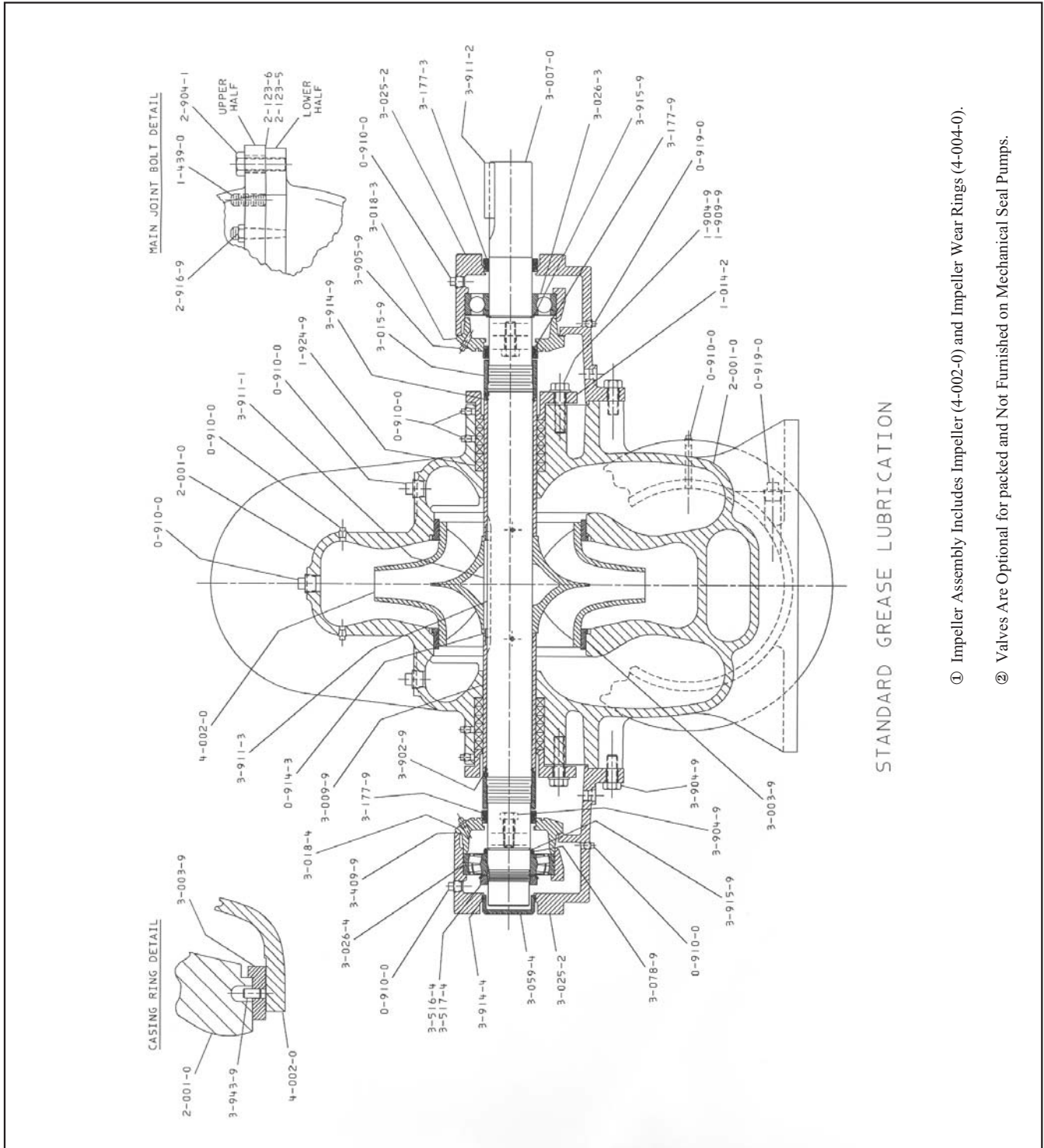

STANDARD GREASE LUBRICATION

- ① Impeller Assembly Includes Impeller (4-002-0) and Impeller Wear Rings (4-004-0).
- ② Valves Are Optional for packed and Not Furnished on Mechanical Seal Pumps.

9100 SERIES CROSS-SECTIONAL

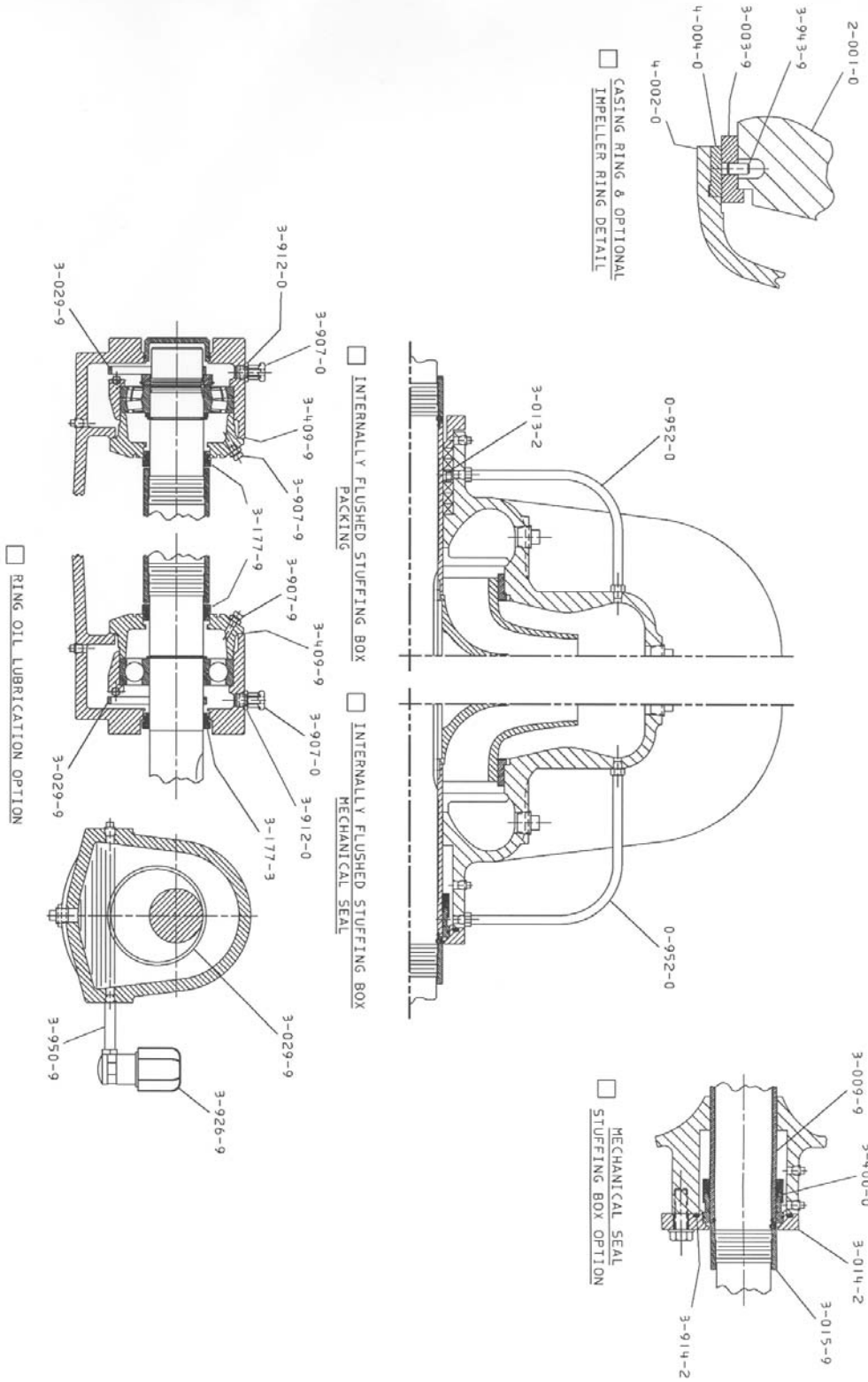

- ① Impeller Assembly Includes Impeller (4-002-0) and Impeller Wear Rings (4-004-0).
- ② Valves Are Optional for packed and Not Furnished on Mechanical Seal Pumps.

APPENDIX V

REPLACEMENT PARTS LIST

ITEM NO.	PART NAME	QTY.
2-001-0	CASING, UPPER HALF	1
2-001-0	CASING, LOWER HALF	1
4-002-0	IMPELLER	1
0-952-0	PIPING	2
3-013-2	LANTERN RING	2
1-924-0*	PACKING, STUFFING BOX	1 SET
1-014-2	GLAND, STUFFING BOX	2
3-018-4	END COVER, IB THR. BRG	1
3-059-4	CAP. BRG. HSG. END	1
3-907-0	BREATHER	2
3-029-4	RING, OIL	2
3-018-3	END COVER, IB CPLG. BRG.	1
3-007-0	SHAFT	1
3-015-9	NUT, SLEEVE	2
3-009-9*	SLEEVE, SHAFT	2
3-003-9*	RING, CASING WEAR	2
3-025-2	HOUSING, BEARING	2
3-516-4	LOCKNUT, BEARING	1
4-004-0	RING, IMPELLER WEAR	2
3-026-3	BEARING, RADIAL BALL	1
3-911-1	KEY, IMPELLER	1
3-950-9	NIPPLE, OILER PIPE	2
3-905-9	FITTING, STRAIGHT DRIVE GREASE	2
3-902-9	SCREW, SLEEVE NUT SET	2
3-014-2	GLAND, MECHANICAL SEAL	2
3-926-9	OILER	2
3-915-9	RING, THR. BRG. RETAINING	1
3-907-9	VENT, AIR	2
3-177-3 / 3-177-9	ISOLATOR, BEARING	3
2-123-6*	GASKET, CASING PARTING DISCH.	1

ITEM NO.	PART NAME	QTY.
2-123-5*	GASKET, CASING PARTING SUCT	1
1-904-9	SCREW, GLAND HEX CAP	4/8
1-909-9	WASHER, GLAND	4/8
0-910-0	PLUG, FRAME OILFILL PIPE	2
0-910-0	PLUG, PIPE FRAME	4
3-409-9	GASKET, END COVER	2
3-904-9	SCREW, HEX (BRG. HSG./END COVER)	4
3-904-9	SCREW, HEX CAP (HSG./CASING)	8
3-517-4	LOCKWASHER, BEARING	1
3-400-0*	SEAL, MECHANICAL	2
3-911-2	KEY, COUPLING	1
3-911-3	KEY, SLEEVE	2
0-910-0	PLUG, CASING PIPE	9
0-910-0	PLUG, CASING PIPE	5
3-026-4	BEARING, THRUST BALL	1
3-914-2*	O-RING, MECHANICAL SEAL	2
1-439-0	BOLT, JACK	2
N/A	PIN, NAMEPLATE	10
2-904-1	SCREW, PARTING HEX CAP	Size Dependent
2-904-1	SCREW, PARTING HEX CAP	Size Dependent
0-914-3	GASKET, SLEEVE	2
N/A	NAMEPLATE, FRAME	1
N/A	NAMEPLATE, CASING	1
N/A	NAMEPLATE, LOGO CASING	2
3-943-9	PIN, ANTIROTATION	2
2-916-9	PIN, TAPER WITH HEX NUT	2
3-914-4	O-RING, END CAP	1
3-914-9*	O-RING, SLEEVE NUT	2
3-078-9	WASHER, BEARING (OUTBOARD)	1
3-912-0	BUSHING, REDUCER	2

APPENDIX VI

USEFUL FORMULAS

1) Head (ft.) = $\frac{\text{Pressure (psig)} \times 2.31}{\text{S.G.}}$ S.G. = Specific gravity; S.G. of water = 1.0 at 70° F

2) TDH (ft.) = Total Dynamic Head (ft.) = (Disch. Pressure gauge reading - Suct. Pressure gauge reading +
(Discharge velocity head - Suction velocity head +
(Elevation correction to disch. gauge - Elevation correction to suct. gauge)

3) PUMP INPUT HP (BHP) - calculated:

Single Phase Motor

$$\text{BHP} = \frac{\text{Amps} \times \text{Volts} \times \eta_m \times \text{p.f.}}{746}$$

Three Phase Motor

$$\text{BHP} = \frac{\text{Avg. Amps} \times \text{Volts} \times 1.732 \times \eta_m \times \text{p.f.}}{746}$$

Where η_m = motor efficiency, p.f. = Motor power factor, Avg. Amps = $\frac{\text{leg 1} + \text{leg 2} + \text{leg 3}}{3}$

4) Pump Efficiency (η_p): $\eta_p = \frac{\text{GPM} \times \text{TDH}}{3960 \times \text{BHP}}$

5) Affinity Laws for correcting GPM, TDH, and BHP for speed (RPM):

$$\frac{\text{GPM}_1}{\text{GPM}_2} = \frac{\text{RPM}_1}{\text{RPM}_2} \quad \text{or} \quad \text{GPM}_1 = \text{GPM}_2 \times \frac{\text{RPM}_1}{\text{RPM}_2}$$

$$\frac{\text{TDH}_1}{\text{TDH}_2} = \left(\frac{\text{RPM}_1}{\text{RPM}_2} \right)^2 \quad \text{or} \quad \text{TDH}_1 = \text{TDH}_2 \times \left(\frac{\text{RPM}_1}{\text{RPM}_2} \right)^2$$

$$\frac{\text{BHP}_1}{\text{BHP}_2} = \left(\frac{\text{RPM}_1}{\text{RPM}_2} \right)^3 \quad \text{or} \quad \text{BHP}_1 = \text{BHP}_2 \times \left(\frac{\text{RPM}_1}{\text{RPM}_2} \right)^3$$

6) NPSHA determination:

NPSHA = Net Positive Suction Head Available

NPSHA = (Atmospheric pressure - Vapor pressure of liquid + Total suction head)

Total Suction Head = (Suction pressure gauge reading + Suction velocity head + Elevation correction to suction gauge)

NOTE: NPSHA must always be greater than NPSHR (NPSHA \geq NPSHR) for the pump to operate without concern of cavitation.

NPSHR refers to Net Positive Suction Head Required by pump. This is a published value obtained from the Pump Manufacturer's curve.

FIELD TEST REPORT

APPENDIX VII

Field Test Report

Date _____

Pump Size _____ Pump Type _____
 Pump Serial Number _____ Impeller Diameter (in.) _____
 Manufacturer's Pump Curve Number _____

RATING: GPM _____ Head _____ RPM _____
 Suction gauge pipe size _____ inches
 Discharge gauge connection pipe size _____ inches
 Discharge gauge elevation corr. _____ feet
 Suction gauge elevation corr. _____ feet

MOTOR:** Rated HP _____ Volts _____ S.F. _____
 F.L. Amps _____ F.L. Eff _____ P.F. _____
 Phase _____

Barometric pressure _____ inches Hg x 1.13 = _____ feet water
 Liquid pumped _____ S.G. _____
 Liquid temperature _____ °F
 Liquid vapor pressure _____ psi x 2.31 = _____ feet water

P O I N T	Discharge Pressure Gauge		Suction Pressure Gauge		Velocity Head (feet)		Total Dynamic Head (TDH ₂)	FLOW		RPM ₂	Motor Volts	Motor Amps			Avg. Amps	Pump BHP ₂ (calc'd)	Pump Eff. (calc'd)	Affinity Law Corrections			Calc'd NPSH _A		
	(PSI)	(ft)	(PSI)	(ft)	Disc.	Suct.		Reading	Convert to GPM ₂			Leg 1	Leg 2	Leg 3				RPM ₁	TDH ₁	GPM ₁		BHP ₁	
1																							
2																							
3																							
4																							
5																							
6																							
7																							
8																							
9																							
10																							

* NPSHR taken from manufacturer's pricebook curve.
 ** Motor information taken off motor nameplate.
 See sheet 2 of 2 for useful formulas.

Type of flow measurement device: _____
 Readings taken by: _____

Comments: _____

HOW TO ORDER PARTS

**When ordering parts, call
1-800-446-8537
or your local A-C Pump Representative**

EMERGENCY SERVICE

**Emergency parts service is available
24 hours / day 365 days / year . . .
Call 1-800-446-8537**

Visit our website at www.acpump.com

A-C Pump

